

التطبيقات المتكاملة للأنابيب ووصلات البولي
إثيلين عالي الكثافة لشبكات المياه والغاز

Integrated Applications for High Density Polythylene Pipes and Fittings for Water & Gas Networks



- PIPE
- INJECTION FITTING
- FABRICATED FITTING
- BUTT FUSION MACHINE
- ELECTRO FUSION FITTING
- ELECTRO FUSION MACHINE





ALwasail



الوسائل

Alwasail Industrial Co. شركة الوسائل الصناعية

Company History

Alwasail Agricultural Company founded in the city of Burydah as an individual corporation in 1399 H corresponding to 1979 G and then it grew and evolved and took specialize in the field of irrigation and then turned into a joint venture company of their respective owners Abdul Rahman Bin Abdullah Almushaygih and his brothers Nasser, Abdulaziz, Saleh and Abdul Qadir.

In 1410 H, corresponding to 1990 G began the first Alwasail Irrigation System Factory to produce Polyethylene Material in accordance to the European and American Specifications.

On 20 Shaaban 1428 H an order issued by Minister of Commerce and Industries to Approve the Transformation of Alwasail Agricultural Company to Alwasail Industrial Company from solidarity firm to Closed Joint Stock company with the capital of 100 Million SAR is divided into 10 Million Shares. The nominal value of share is 10 SAR for the subscribed founders and the Capital was paid fully. The base office for the company taken in city of Burydah .

The Purposes of the company : (Production of the plastic Pipes (Polyethylene) of different sizes and lengths for Irrigation Systems, Drinking Water, Sanitation, Electricity Conduits , Telecom Ducts and their Accessories , Rubber Rings Joints and seals.

Contractor work for the Water and Sanitation, Maintenance and operation of Water and Sanitation, Whole Sale and Retail trading of Company Products , Own Real Estates and Constructions of Buildings and warehouses needed to achieve its objectives and Storage of Products, Marketing of company's products within the Kingdom of Saudi Arabia and outside (Worldwide).

The Duration of the Company will be Ninety Nine Year beginning from the date of the issuance of Ministerial Declaration of Transforming the company and the duration may prolong by the decision of the extraordinary General Assembly of the Company.

The Company's Management and Board of Directors Consisting of Five Members appointed by the ordinary General Assembly for the period of three years and was appointed the first board of directors of the company for the Period of three years.

The ministry has shown that the approval of the transformation of this company comes within the framework of state policy efforts to expand the economic base and diversify sources of national income and encourage the private sector is going to play an active role in advancing economic development.

Purposes of the Alwasail Industrial Company as Stated in the statute.

Purposes of the company's as below

- Production of Plastic Pipes(Polyethylene) of various sizes and lengths for Irrigation Systems, Drinking Water, Sanitation , Electrical Conduits, Telecom Ducts and their Fittings and Accessories.
- Production of Rubber rings and joints.
- Contracting work for the Drinking Water and Sanitation, operation and Maintenance of Drinking Water Supplies and sanitation Networks.
- Wholesale and Retail Trade of Company's Products.
- Own Real Estates and Construction of Buildings and Warehouses needed to achieve its objectives and to store products.
- Marketing the Product of the company within the Kingdom of Saudi Arabia and Abroad (Worldwide Export).

Company History

The Company Operates after obtaining Necessary Licenses from the competent Authority. The shift to Transfer the Family Company (joint venture) to Closed Joint Stock Company is very important step for continuation.

The Company Owns Several Factories which are specialized and the most important of them are Alwasail Irrigation System Factory and Alwasail Polyethylene Pipes and Saudi Rubber Products.

These factories Produce Polyethylene Pipes, Fittings and Accessories of more than one thousand kinds of different sizes for irrigations systems water works etc.

Also Saudi Rubber Factory Produces Rubber joints and rubber rings and this factory plant are one of the most important rubber factories in the Kingdom.

The Most Important Roles of the Company is to contribution and realization of its products and technology in the use of Water in Kingdom of Saudi Arabia

The Company Also Participated in the development of Modern Agriculture through provision of complete solution of sprinkler irrigation , drip irrigations , rationalization of water use in farms , Gardens and parks in the last there decades.

Recently company entered the production of pipes and fittings of many diverse purposes.

- Company Exports its products to more than 40 Countries Worldwide.
- is largest customers of Sabic's polyethylene.
- 25 branches with in the kingdom of Saudi Arabia.
- Has Branches , agents and Authorized distributors in Gulf, Arab Countries and Worldwide.
- Member of the Organization of American Irrigation.
- ISO Certified.
- Holds A shield from SABIC .
- Approved from Saudi Aramco.
- Holds the shields and certificates for participation in the Festivals and Events.
- Holds shields and certificates in the support of charitable Projects.
- Holds shields and certificates in the economic, educational and social development.
- The Company has complete management of the implementation of the Government projects and for all kinds of irrigation networks and water and projects for Parks and gardens.
- Telecommunication Projects and Fiber Optics Layouts.
- Gas Projects.
- Environmental Projects .
- Irrigation Projects for Major Agricultural developments for Private sectors.

Company History

Alwasail Industrial Company has Implemented Many Infrastructure Projects in United Arab Emirates, Qatar and other countries.

The Manufacturing Plants (Factories) located on an area of more than 160,000.00 m² Square Meters.

The Company Officials are very keen to participate in the local, GCC, Arab and international Forums and Exhibitions in the Areas of Irrigation, Water, Rubber and Plastic and others.

The Company owns laboratories in its factories for measuring and testing products to ensure the safety and comply with various quality standards.

The Company owns an advanced workshop which is heart of factory Research and Development where it produces and implements and develops product moulds.

The maintenance of machinery and equipments are mostly done by company. The company holds the vast experience and information in the various fields that is a valuable information asset for our dear country.

The experiences and information in the field of work locally and globally is an honor to the company and our beloved Country.

In Addition to purchasing Raw Material from SABIC the company buys a lot of it needs such as Raw materials, tools and spare parts from other suppliers and local market.

The company deals with many others in the areas of Computers and software and many other service Provides.

The Company's Factories receive many visitors from experts and specialists from within the Kingdom and abroad to exchange expertise and experiences.

The company allows visits to lots of customers interested and government officials from agricultural departments, water and irrigation, Telecom, Municipalities and others .

With the Continued growth of the Saudi Arabian Economy and Industrial Developments under the Government of the Custodian of the Two Holy Masjids King Abdullah Bin Abdul Aziz and Crown Prince and Secretary Alwasail Industrial Company aspire to develop its inception and expansion of production and delivery of services to entire Saudi Arabian Market and spread around the World.

Company History	05 - 03
Table of Contents	08 - 06
Introduction	10
Field of Application	11
High Density Polyethylene Pipes	
HDPE Pressure Pipe PE 100 = mrs 10 = sigma 8.0	12
HDPE Pressure Pipe PE 80 = mrs 8 = sigma 6.4	13
HDPE Pressure Pipe PE 80 = mrs 8 = sigma 5.0	14
HDPE Perforated Pipe	15
HDPE Slotted Pipe	16
High Density Polyethylene Pipes	
Flange Adaptor (Stub End)	18
Steel Flange PN 10	19
Steel Flange PN 16	20
Steel Flange & End cap	21
Tee & Tee & Reducer	22
Reducer & 90 Elbow	23
Butt Welding- Fabricated Fittings	
90 Elbow & 45 Elbow	24
Tee - PE 100 & PE 80	25
Tee - Reducer (MKM)	26
Tee - Reducer (MKM)	27
Tee - Reducer (MKM)	28
Tee - Reducer (MKM)	29

Butt Fusion Welding Machine

Hydraulic butt fusion welding machine delta dragon 250b	30
Butt fusion welding machine delta dragon 355b	31
Butt fusion welding machine delta 630	32
Basic line vs delta dragon differences (electro-hydraulic case)	33
Basic line vs delta dragon differences (machine body)	34
Basic easy life	35
Basic 200-160	36
Basic 250	37
Welding General Criteria	46 - 38
Parts Description	53 - 47
Maintenance	56 - 54

Butt Fusion Welding Machine

Safety Precaution	59 - 57
Butt fusion welding machine Basic 355	60

Electro Fusion Fittings

Electrofusion fittings Pressure ratings	62
Electrofusion fittings	63
Coupler & End Cap	64
Reducer & °90 Elblow	65
°45 Elblow & Equal Tee	66
Multiseal Tapping Tee U/P	67
Male & Female Transition Couper	68

Electro Fusion Welding Machine

Q Box Electrofusion Control Box	70
Electra 400 & Electra 800	71
Technical Features	72
Parts Description	73
Control Panel	75 - 74
Technical Features	78 - 76
Connection & Generators Features	79

Approval and Certificate

TUV NORD	80
NSF	81
WRAS	82
BUREAU VERITAS	83
BUREAU VERITAS	84
BUREAU VERITAS	85
SAUDI ARAMCO	86
NATIONAL WATER COMPANY	87
NATIONAL WATER COMPANY	88

Notes

Notes	93 - 90
Address	94

INTRODUCTION

Polyethylene piping systems are used all over the world for the supply and conveying of several kinds of media, including liquid, gas and powers as well as in mining and quarry applications.

Polyethylene pipe work systems have the main advantages over steel and ductile iron systems it lighthtness of weight and freedom from corrosion. The rapid growth in use of polyethylene is due in part to benefits over steel and iron systems, but possibly more to the development of several ad – vanced and easy jointing techniques. Polyethylene has very good fatigue strength and special provision for surges frequently allowed when designing other thermoplastic pipe work systems (as PVC) are not normally necessary.

In 1990 Alwasail Industrial Company started its production of High Density Polyethylene (HDPE) piping systems, low-density polyethylene (LDPE) piping systems.

Pipes (HDPE) are production in size up to 1200 mm in diameter, with nominal pressure rating PN4, PN6, PN10, up to PN 16 (other pressure ratings also available). All pipes and fittings are manufactured in accordance with current European standards, DIN 8074, IOS 4427, / 1167 and SASO Draft No. 5208 and European Standard as EN 1220 1- 2 for Pipes EN 1220 1-3 for Fittings.

HDPE piping system are used worldwide for conveying of water as well as for transportation of hazardous fluids. It offers the following advantages to the customer.

Advantages

- Low specific Weight
- Excellent weldability
- Smooth inside surface, no deposits and on overgrowth
- Due to less frictional resistance, less pressure drop compared to metals
- Suitable for food and potable water
- Complies with the food stuff regulations
- Approved and registered for potable water supply
- Laying speed ease joining and reliability

Resistance to :

- Ultraviolet rays
- Weathering
- Chemicals
- Heat aging
- Abrasion
- Rodents
- Freezing
- Microbes freezing

FIELDS OF APPLICATION

HDPE pipes have been in existence since the mid 50s. The experience shows that HDPE pipes is the solution most pipe problems being recognized by clients and engineering consultants as the ideal pipe material for many pressure and non pressure application from water and gas distribution to gravity, Sewers and surface water drainage for both new & Rehabilitation Project. Alwasail polyethylene pipes is based on a polyolefin thermoplastic resin which is also a physiologically non-toxic material, therefore, it is suitable for a wide range of application.

Water Supply. Alwasail PE pipes are made from material meeting the toxicity requirement of the WHO and this can be used for transportation of drinking water.

- Pipes and fittings with pressure ratings of SDR 7.4 up to SDR 41 for water mains as well as distribution piping systems and service lines.
- Drain pipes and fittings for spring water chamber pipes.
- Ascending pipes for wells.

In contrast for pipes made of steel or ductile iron, HDPE piping systems are light weight corrosion resistant. Neither sour soils nor *aggressive* water will have no effect to the material. Additionally, corrosion products, which often impair the operability of the piping systems, are avoided. In comparison to PVC pipes, HDPE pipes are more flexible and offer high impact resistance even in zero temperatures. The pipes may be adapted easily to the trench layout without employing additional fittings.

On the other hand, fracture risks due to extreme handling condition on the construction site are minimized. HDPE piping systems (spigot and socket joints) offer a range of longitudinal frictional connection methods. Thus, the installation of anchors or thrust blocks is not necessary and a leak proof piping system with a long life is guaranteed.

Highest drinking water quality. The suitability of the material for drinking water is ensured through independent tests. Neither the taste nor the smell of the drinking water is affected due to the contact with HDPE pipes. The smooth surface and the high abrasion resistance guarantee minimum deposits. Polyethylene is corrosion resistant, therefore, the drinking water cannot be contaminated with corrosion by-products like copper or heavy metals such as cadmium or lead, which happens frequently with older metal piping systems.

Environmental Friendly material for a clean environment. The HDPE pipes and fitting are exclusively made from the environmentally friendly materials. For instance, the energy requirements for the production of HDPE pipes lower comparison to metallic pipes. Furthermore, on hazardous substances, which may endanger or may pollute the environment, result from the production of the pipes is made of polyethylene. The application of HDPE the best solution for the environment. A 100% leak proof supply system may be installed with simple welding methods. Thus, endangering the drinking water with toxic substances is reduced. Additional, water loss due to leaking piping systems are avoided. No other supply system offers these advantages.

For extreme conditions. HDPE piping systems are approved for installation in all types of soil. Polyethylene is a flexible and tough pipe material. Thus, these systems are especially suitable for installation in soils susceptible to ground material. The application of various jointing methods encases a leak proof supply system. Due to the light weight and the simple jointing methods, HDPE pipes are very well suitable for unfavorable condition – for the installation in difficult terrain.

Drainage. Alwasail pipes are being used for underground drainage for buildings, waste lines for corrosive fluids and also as plumbing material for house drainage. They can also be used sewer works. Due to its very good chemical resistance, HDPE as a perfect material for the manufacturer of large bore for sewage systems. They are ideally suited for industrial waste disposal and are being used to an increasing extent as underground sewer waste pipes.

Industry. Features like corrosion – resistance, easy installation, light weight, and flexibility make Alwasail pipes ideal for complicated plumbing in factories. They are ideal for corrosive chemicals.

Gas and Oil Pipeline Systems. PE pipes to line carbon steel pipes to transport oil & gasses at higher pressure are available. The pipes are specially designed with a smooth surface and made easy to install. Thus gas line can be installed at low costs. In drilling they are used as shot-hole casings as they are cheaper. Due to the excellent properties of HDPE, with exhibit a high impact strength and very good resistance aggressive soils. Combined with ease of handling and installation, the HDPE pipes are excellent for transporting material and other gas types including bio-gas.

Quality

This is reflected in national and international certificates ,but above all in the satisfaction of Al WASAll clients, installers and planners the following laws, decrease, guidelines and standards have to be con-sidered on planning and designing al wasall for potable water and heating installations, Cables, Drain-age sewage and well pipe systems.

System specific standards

General quality requirements, dimensions according to:

DIN ,ISO ,EN ,ASTM ,BS ,ES standard for all products **HDPE**

System control

The production of a quality controlled pipe systems demands the supervision, regulation and control of all work operations. All results and processes have to be documented.

This requires

- ✓ Test.and acceptance of incoming goods
- ✓ Process control
- ✓ In-process inspection and test
- ✓ Final inspection and test

Relevant regulations for the quality assurance of all pipes systems are

150- guidelines
ISO 9001/2008
ISO 14001/2004
OHSAS 18001/2007

These standards and guidelines detail the minimum requirements for internal control. Conformance to the standards is verified by independent institutes in form of internal audits and laboratory tests.

al wasail has many years of experience in extrusion and injection molding and is the market leader and pioneer in the manufacturing of **HDPE pipe and fittings systems** .

This experience is reflected in internal quality standards and laid down procedures, which are taken strongest note of and are documented by the constant quality of our products.

Internal control

Trained and qualified employees and a modern equipped laboratory ensure that all tests are carried out and regulations are complied with in accordance with the quality control policy, which includes

- ✓ Control of inspection, measuring and test equipment
- ✓ Process and production control
- ✓ receiving inspection test
- ✓ In-process inspection
- ✓ Final inspection

All internal quality controls are documented and recorded in accordance with the quality control policy.

Process control

ALWASAIL quality control team has supervision of all machines. They inspect all finished products (systemized sampling) all over the day and at the storage too.

They have high experience and training at the quality measurements of the material and finished products.

In-process inspection and test the quality plan requires that tests and inspections are carried out before and during production. At the start of production all quality relevant data are checked by the quality assurance department. Preproduction samples are tested by the laboratory technicians for

- ✓ Surface finish
- ✓ Dimensional accuracy of the test samples
- ✓ Data from extrusion and injection molding machines

The goods will be released for production only if optimal test results are achieved.

These tests are carried out at the beginning of each production series to ensure perfect system quality.

Final Inspection and test

The quality plan requires that inspections and tests are carried out on all finished products.

The results are documented in test reports. Finished products are only released to stock when all tests and inspections conform to the prescribed procedures and specifications.

The final inspection and test includes time lapse test procedures.

This enables statements regarding the usability of the products in their later field of application.

These tests are the method for quality assurance during production and for design tests.

This is to discover and remove production weaknesses.

The results document the system quality and optimize the manufacturing processes.

The final inspection and test covers a lot of test explaining in detail.

Polyethylene (PE)

General Information

Polymers which consist only of carbon and hydrogen (hydrocarbons) are called polyolefin. Polyethylene (PE) belongs to this group. It is a semi-crystalline thermoplastic. Polyethylene is the best known standard polymer. The chemical formula is: $(CH_2-CH_2)_n$. It is an environmentally friendly hydrocarbon product so that it's the most common plastic.

PE is considered a non-polar material, meaning it does not dissolve in common solvents and hardly swells. As a result, PE pipes cannot be solvent cemented. The appropriate joining method for this material is heat fusion.

HDPE: High Density Polyethylene (PE 100)

DESCRIPTION

- PE 100 is a black high density polyethylene designed for water pressure pipes, irrigation, chemical industrial and underground drainage.
- PE 100 contains minimum 2% of well dispersed, fine particle size Carbon Black and stabilizers to ensure excellent weathering resistance and long-term stability.
- PE 100 shows excellent resistance to rapid crack propagation and slow crack growth, both being important parameters for pressure pipe design.
- PE 100 can easily be welded by butt fusion, using standard HDPE parameters or by electrofusion.
- PE 100 raw material has the highest performance of all HDPE material (PE 63 and PE 80)

Material Properties (PEI00)

Material Data

The following table lists typical physical properties of Polyethylene thermoplastic materials. Variations may exist depending on specific compounds and product.

PHYSICAL PROPERTIES	Typical Value	Unit	Test Method
Density (Base resin)	949	Kg/m ³	ISO 1183/150 1872-28
Density (Compound)	959	Kg/m ³	ISO 1183/150 1872-28
Melt Flow Rate (190°C/2.16kg)	<0.1	g/10min	ISO 1133
Melt Flow Rate (190°C/5.0kg)	0.25	g/10min	ISO 1133
Tensile Stress at Yield 50mm/min	25	Mpa	150527-2
Elongation at Break	>600	%	ISO 527-2
Charpy impact, notched (0°C)	16	KJ/m ²	ISO 179/1eA
Hardness, Shore D	60	-	150868
Carbon Black Content	~2	%	A5TM D 1603
Brittleness Temperature	<-70	°C	A5TM D746
ESCR (10% Igepal), F ₅₀	>10000	h	A5TM D 1693-A
Thermal Stability (210°C)	>15	min	EN 728

The Advantages of PE 100

High Impact Strength:

The high impact strength of PE 100 pipes compared with other materials ensures a greater resistance to the rigours of pipe laying conditions.

Damage Resistance:

PE 100 has low notch sensitivity, providing a high level of resistance to the effect of external damage, especially important for pipe bursting operations and others where likelihood such damage.

Ease of Installation:

PE 100 pipes are easy to install with their light weight and long lengths. PE coiled pipes are widely used in applications such as stock watering, irrigation systems, communications, gas, and reticulated water mains due to rapid installation and the ease and less frequent joining.

High Flow Capacity:

HDPE pipes have lower friction factors than the most non-plastic materials. The surface energy characteristics of PE 100 ensure that material deposition is inhibited and the smooth bore characteristic is maintained over the working life of pipe line.

Long life:

Burst Stress MPa

PE 100 pipes have a proven high reliability record across a wide range of industries and applications, now approaching a period of 50 years. PE 100 also provides a long maintenance free lifetime with low whole life costs, compared to many other materials. (fig.1)

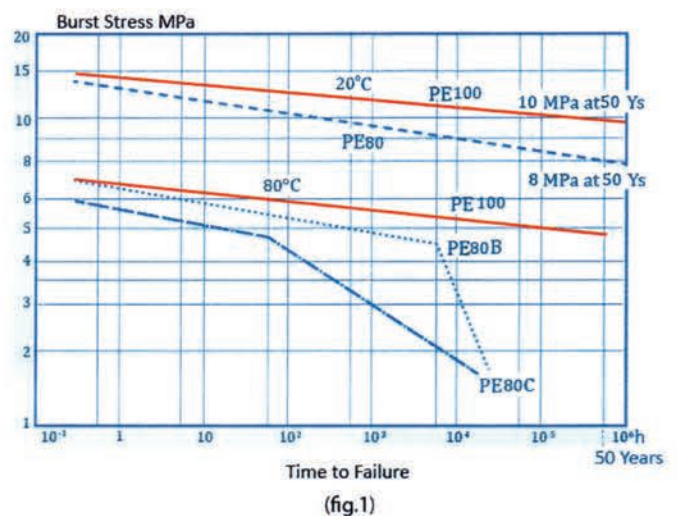

Trenchless Construction:

PE 100 pipes offer many advantages in slip lining, pipe bursting, directional drilling and microtunneling including features such as long lengths, corrosion resistance, light weight and ease of installation with minimum disruption.



ALWASAIL



الوسائل

شركة الوسائل الصناعية

Alwasail Industrial Co.

High Density Polyethylene Pipes

HOPE Pressure Pipe PE 100 = MRS 10 = sigma 8.0	12
HOPE Pressure Pipe PE 80 = MRS 8 = sigma 6.4	13
HOPE Pressure Pipe PE 80 = MRS 8 = sigma 5.0	14
HOPE Perforated Pipe	15
HOPE Sioted Pipe	16
Transportation, Packing , handling and stovage of PE 100 pipes	17

HDPE PRESSURE PIPE PE100 = MRS 10 = SIGMA

Dimensioning according to DIN 8074 – ISO 4427 / 1167

Material
High Density Polyethylene PE100
MRS = 10 Mpa
 $\sigma_s = 8 \text{ Mpa (MRS / c)}$
c = 1.25

Color
Black

Dimensions
DIN 8074 / 8075

Standard Length

- Up to Dia 180 Coils
- Dia 90 to 1200 Lengths & Specil Lengths are available Up on request

Available on Request

- Other length
- Color
- Pipe in other PN/SDR classes according to DIN 8074 / 8075

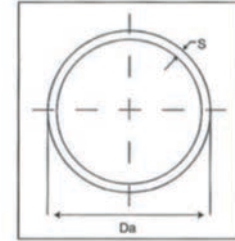

$$PN = \frac{2 \times \sigma_s \times s \times 10}{Da - s}$$

Pipe Series = $\sigma_s \times 10 / PN$

Note

PN Nominal Pressure (Bar)
Wt Pipe weight (Kg/m)
S Wall thickness (mm)
Da Nominal Outside Diameter (mm)
SDR Standard dimensional ratio (Da/s)
MRS Minimum required strength (Mpa)
 σ_s Hydrostatic Design stress@20c
C Design factor 1.25 for water

*** Weight may vary according to polymer density. The mass has been calculated taking average density as 0.95 g/cm3. For other densities, the mass shall be established by linear interpolation, taking the wall thickness as the nominal size plus half the tolerance specified.

NOMINAL OUTSIDE DIAMETER	PIPE SERIES																	
	S20			S 12.5			S 8			S 6.3			S 5			S 4		
	Standard Dimension Ratio																	
	SDR 41			SDR 26			SDR 17			SDR 13.6			SDR 11			SDR 9		
Da	Nominal Pressure PN for $\sigma_s = 8 \text{ Mpa}$																	
	PN 4			PN 6.3			PN 10			PN 12.5			PN16			PN20		
mm	Nominal Pipe I.D mm	Wall Thickness mm	Approx. weight kg/m	Nominal Pipe I.D mm	Wall Thickness mm	Approx. weight kg/m	Nominal Pipe I.D mm	Wall Thickness mm	Approx. weight kg/m	Nominal Pipe I.D mm	Wall Thickness mm	Approx. weight kg/m	Nominal Pipe I.D mm	Wall Thickness mm	Approx. weight kg/m	Nominal Pipe I.D mm	Wall Thickness mm	Approx. weight kg/m

12																		
16																12.4	1.8	0.084
20									16.4	1.8	0.107	16.2	1.9	0.112	15.4	2.3	0.133	
25							21.4	1.8	0.137	21.2	1.9	0.144	20.4	2.3	0.171	19.4	2.8	0.200
32							28.2	1.9	0.187	27.2	2.4	0.232	26.2	2.9	0.272	24.8	3.6	0.327
40				36.4	1.8	0.227	35.2	2.4	0.295	34.0	3.0	0.356	32.6	3.7	0.430	31.0	4.5	0.509
50				46.0	2.0	0.314	44.0	3.0	0.453	42.6	3.7	0.549	40.8	4.6	0.666	38.8	5.6	0.788
63	59.4	1.8	0.364	58.0	2.5	0.494	55.4	3.8	0.721	53.6	4.7	0.873	51.4	5.8	1.050	48.8	7.1	1.260
75	71.2	1.9	0.457	69.2	2.9	0.675	66.0	4.5	1.020	63.8	5.6	1.240	61.4	6.8	1.470	58.2	8.4	1.760
90	85.6	2.2	0.643	83.0	3.5	0.978	79.2	5.4	1.460	76.6	6.7	1.770	73.6	8.2	2.120	69.8	10.1	2.540
110	104.6	2.7	0.943	101.6	4.2	1.430	96.8	6.6	2.170	93.8	8.1	2.620	90.0	10.0	3.140	85.4	12.3	3.780
125	118.8	3.1	1.230	115.4	4.8	1.840	110.2	7.4	2.760	106.6	9.2	3.370	102.2	11.4	4.080	97.0	14.0	4.870
140	133.0	3.5	1.540	129.2	5.4	2.320	123.4	8.3	3.460	119.4	10.3	4.220	114.6	12.7	5.080	108.6	15.7	6.110
160	152.0	4.0	2.000	147.6	6.2	3.040	141.0	9.5	4.520	136.4	11.8	5.500	130.8	14.6	6.670	124.2	17.9	7.960
180	171.2	4.4	2.490	166.2	6.9	3.790	158.6	10.7	5.710	153.4	13.3	6.980	147.2	16.4	8.420	139.8	20.1	10.100
200	190.2	4.9	3.050	184.6	7.7	4.690	176.2	11.9	7.050	170.6	14.7	8.560	163.6	18.2	10.400	155.2	22.4	12.400
225	214.0	5.5	3.860	207.8	8.6	5.890	198.2	13.4	8.930	191.8	16.6	10.900	184.0	20.5	13.100	174.6	25.2	15.800
250	237.6	6.2	4.830	230.8	9.6	7.300	220.4	14.8	11.000	213.2	18.4	13.400	204.6	22.7	16.200	194.2	27.9	19.400
280	266.2	6.9	5.980	258.6	10.7	9.100	246.8	16.6	13.700	238.8	20.6	16.800	229.2	25.4	20.300	217.4	31.3	24.300
315	299.6	7.7	7.520	290.8	12.1	11.600	277.6	18.7	17.400	268.6	23.2	21.200	257.8	28.6	25.600	244.6	35.2	30.800
355	337.6	8.7	9.550	327.8	13.6	14.600	312.8	21.1	22.100	302.8	26.1	26.900	290.6	32.2	32.500	275.6	39.7	39.100
400	380.4	9.8	12.100	369.4	15.3	18.600	352.6	23.7	28.000	341.2	29.4	34.100	327.4	36.3	41.300	310.6	44.7	49.600
450	428.0	11.0	15.300	415.6	17.2	23.500	396.6	26.7	35.400	383.8	33.1	43.200	368.2	40.9	52.300	349.4	50.3	62.700
500	475.4	12.3	19.00	461.8	19.1	28.900	440.6	29.7	43.800	426.4	36.8	53.300	409.2	45.4	64.500	388.4	55.8	77.300
560	532.6	13.7	23.600	517.2	21.4	36.200	493.6	33.2	54.800	477.6	41.2	66.900	458.4	50.8	80.800	435.0	62.5	97.00
630	599.2	15.4	29.900	581.8	24.1	45.900	555.2	37.4	69.400	537.4	46.3	84.600	515.6	57.2	102.000	-	-	-
710	675.2	17.4	38.00	655.6	27.2	58.400	625.8	42.1	88.100	605.6	52.2	107.00	581.0	64.5	130.00			
800	760.8	19.6	48.100	738.8	30.6	73.900	705.2	47.4	112.00	682.4	58.8	136.00						
900	856.0	22.0	60.900	831.2	34.4	93.400	793.4	53.3	141.00	767.8	66.1	172.00						
1000	951.0	24.5	75.200	923.6	38.2	115.00	881.4	59.3	175.00									
1200	1141.2	29.4	108.00	1108.2	45.9	166.00												

HDPE PRESSURE PIPE PE80 = MRS 8 = SIGMA 6.4

Dimensioning according to DIN 8074 - ISO 4472 / 1167

Material
High Density Polyethylene PE80
MRS = 8.0 Mpa
 $\sigma_s = 6.3 \text{ Mpa (MRS / c)}$
c = 1.25

Color
Black

Dimensions
DIN 8074 / 8075

Standard Length

- Up to Dia 180 Coils
- Dia 90 to 1200 Lengths & Specil Lengths are available Up on request

Available on Request

- Other length
- Color
- Pipe in other PN/SDR classes according to DIN 8074 / 8075

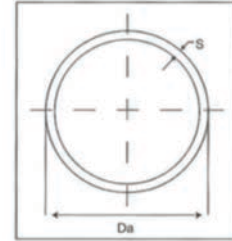

$$PN = 2 \times \sigma_s \times s \times 10$$

$$Da - s$$

$$\text{Pipe Series} = \sigma_s \times 10 / PN$$

Note

PN Nominal Pressure (Bar)
Wt Pipe weight (Kg/m)
S Wall thickness (mm)
Da Nominal Outside Diameter (mm)
SDR Standard dimensional ratio (Da/s)
MRS Minimum required strength (Mpa)
 σ_s Hydrostatic Design stress@20c
C Design factor 1.25 for water

*** Weight may vary according to polymer density. The mass has been calculated taking average density as 0.95 g/cm³. For other densities, the mass shall be established by linear interpolation, taking the wall thickness as the nominal size plus half the tolerance specified.

NOMINAL OUTSIDE DIAMETER	Pipe Series																	
	S20			S 16			S 10.5			S 6.3			S 5			S 4		
	Standard Dimension Ratio																	
	SDR 41			SDR 33			SDR 22			SDR 13.6			SDR 11			SDR 9		
Da mm	Nominal Pressure PN for $\sigma_s = 6.4 \text{ Mpa}$																	
	PN 3.2			PN 4			PN 6			PN 10			PN 12.5			PN 16		
	Nominal Pipe I.D mm	Wall Thickness mm	Approx. weight kg/m	Nominal Pipe I.D mm	Wall Thickness mm	Approx. weight kg/m	Nominal Pipe I.D mm	Wall Thickness mm	Approx. weight kg/m	Nominal Pipe I.D mm	Wall Thickness mm	Approx. weight kg/m	Nominal Pipe I.D mm	Wall Thickness mm	Approx. weight kg/m	Nominal Pipe I.D mm	Wall Thickness mm	Approx. weight kg/m

12																			
16																12.4	1.8	0.084	
20										16.4	1.8	0.107	16.2	1.9	0.112	15.4	2.3	0.133	
25										21.2	1.9	0.144	20.4	2.3	0.171	19.4	2.8	0.200	
32										27.2	2.4	0.232	26.2	2.9	0.272	24.8	3.6	0.327	
40							36.2	1.9	0.238	34.0	3.0	0.356	32.6	3.7	0.430	31.0	4.5	0.509	
50				46.4	1.8	0.287	45.4	2.3	0.361	42.6	3.7	0.549	40.8	4.6	0.666	38.8	5.6	0.788	
63	59.4	1.8	0.364	59.0	2.0	0.399	57.2	2.9	0.563	53.6	4.7	0.873	51.4	5.8	1.050	48.8	7.1	1.260	
75	71.2	1.9	0.457	70.4	2.3	0.551	68.0	3.5	0.807	63.8	5.6	1.240	61.4	6.8	1.470	58.2	8.4	1.760	
90	85.6	2.2	0.643	84.4	2.8	0.791	81.8	4.1	1.140	76.6	6.7	1.770	73.6	8.2	2.120	69.8	10.1	2.540	
110	104.6	2.7	0.943	103.2	3.4	1.170	100.0	5.0	1.670	93.8	8.1	2.620	90.0	10.0	3.140	85.4	12.3	3.780	
125	118.8	3.1	1.230	117.2	3.9	1.510	113.6	5.7	2.160	106.6	9.2	3.370	102.2	11.4	4.080	97.0	14.0	4.870	
140	133.0	3.5	1.540	131.4	4.3	1.880	127.2	6.4	2.720	119.4	10.3	4.220	114.6	12.7	5.080	108.6	15.7	6.110	
160	152.0	4.0	2.000	150.2	4.9	2.420	145.4	7.3	3.540	136.4	11.8	5.500	130.8	14.6	6.670	124.2	17.9	7.960	
180	171.2	4.4	2.490	169.0	5.5	3.070	163.6	8.2	4.470	153.4	13.3	6.980	147.2	16.4	8.420	139.8	20.1	10.100	
200	190.2	4.9	3.050	187.6	6.2	3.840	181.8	9.1	5.510	170.6	14.7	8.560	163.6	18.2	10.400	155.2	22.4	12.400	
225	214.0	5.5	3.860	211.2	6.9	4.770	204.4	10.3	7.000	191.8	16.6	10.900	184.0	20.5	13.100	174.6	25.2	15.800	
250	237.6	6.2	4.830	234.6	7.7	5.920	227.2	11.4	8.590	213.2	18.4	13.400	204.6	22.7	16.200	194.2	27.9	19.400	
280	266.2	6.9	5.980	262.8	8.6	7.400	254.4	12.8	10.800	238.8	20.6	16.800	229.2	25.4	20.300	217.4	31.3	24.300	
315	299.6	7.7	7.520	295.6	9.7	9.370	286.2	14.4	13.600	268.6	23.2	21.200	257.8	28.6	25.600	244.6	35.2	30.800	
355	337.6	8.7	9.550	333.2	10.9	11.800	322.6	16.2	17.300	302.8	26.1	26.900	290.6	32.2	32.500	275.6	39.7	39.100	
400	380.4	9.8	12.100	375.4	12.3	15.100	363.6	18.2	21.900	341.2	29.4	34.100	327.4	36.3	41.300	310.6	44.7	49.600	
450	428.0	11.0	15.300	422.4	13.8	19.000	409.0	20.5	27.700	383.8	33.1	43.200	368.2	40.9	52.300	349.4	50.3	62.700	
500	475.4	12.3	19.000	469.4	15.3	23.400	454.4	22.8	34.200	426.4	36.8	53.300	409.2	45.4	64.500	388.4	55.8	77.300	
560	532.6	13.7	23.600	525.6	17.2	29.400	509.0	25.5	42.800	477.6	41.2	66.900	458.4	50.8	80.800	435.0	62.5	97.000	
630	599.2	15.4	29.900	591.4	19.3	37.100	572.6	28.7	54.100	537.4	46.3	84.600	515.6	57.2	102.000	-	-	-	
710	675.2	17.4	38.000	666.4	21.8	47.200	645.4	32.3	68.700	605.6	52.2	107.000	581.0	64.5	130.000				
800	760.8	19.6	48.100	751.0	24.5	59.700	727.2	36.4	87.200	682.4	58.8	136.000							
900	856.0	22.0	60.900	844.8	27.6	75.600	818.0	41.0	110.000	767.8	66.1	172.000							
1000	951.0	24.5	75.200	938.8	30.6	93.100	909.0	45.5	136.000										
1200	1141.2	29.4	108.000	1126.6	36.7	134.000	1090.8	54.6	196.000										

HDPE PRESSURE PIPE PE80 = MRS 8 = SIGMA 5.0

Dimensioning according to DIN 8074 – ISO 4427 / 1167

Material

High Density Polyethylene PE80
MRS = 8.0 Mpa
Os = 5.0 Mpa (MRS / c)
c = 1.6

Note:

PN Nominal Pressure (Bar)
Wt Pipe weight (Kg/m)
S Wall thickness (mm)
Da Nominal Outside Diameter (mm)
SDR Standard dimensional ratio (Da/s)
MRS Minimum required strength (Mpa)
Os Hydrostatic Design stress@20c
C Design factor 1.6 for water

Color

Black

Dimensions

DIN 8074 / 8075

Standard Length

- Up to Dia 180 Coils
- Dia 90 to 1200 Lengths & Specil Lengths are available Up on request

Available on Request

- Other length
- Color
- Pipe in other PN/SDR classes according to DIN 8074 / 8075

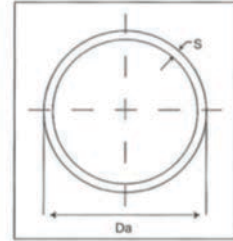

$$PN = \frac{2 \times Os \times s \times 10}{Da - s}$$

Pipe Series = $Os \times 10 / PN$

*** Weight may vary according to polymer density. The mass has been calculated taking average density as 0.95 g/cm3. For other densities, the mass shall be established by linear interpolation, taking the wall thickness as the nominal size plus half the tolerance specified.

NOMINAL OUTSIDE DIAMETER	PIPE SERIES																	
	S16			S 12.5			S 8.5			S 5			S 4			S 3.2		
	Standard Dimension Ratio																	
	SDR 33			SDR 26			SDR 17.6			SDR 11			SDR 9			SDR 7.4		
Da	Nominal Pressure PN for Os = 5 Mpa																	
	PN 3.2			PN 4			PN 6			PN 10			PN 12.5			PN16		
mm	Nominal Pipe I.D mm	Wall Thickness mm	Approx. weight kg/m	Nominal Pipe I.D mm	Wall Thickness mm	Approx. weight kg/m	Nominal Pipe I.D mm	Wall Thickness mm	Approx. weight kg/m	Nominal Pipe I.D mm	Wall Thickness mm	Approx. weight kg/m	Nominal Pipe I.D mm	Wall Thickness mm	Approx. weight kg/m	Nominal Pipe I.D mm	Wall Thickness mm	Approx. weight kg/m

12																8.4	1.8	0.060
16													12.4	1.8	0.084	11.6	2.2	0.099
20							16.4	1.8	0.107	16.2	1.9	0.112	15.4	2.3	0.133	14.4	2.8	0.154
25							21.4	1.8	0.137	20.4	2.3	0.171	19.4	2.8	0.200	18.0	3.5	0.240
32							28.4	1.8	0.179	26.2	2.9	0.272	24.8	3.6	0.327	23.2	4.4	0.386
40				36.4	1.8	0.227	35.4	2.3	0.285	32.6	3.7	0.430	31.0	4.5	0.509	29.0	5.5	0.600
50	46.4	1.8	0.287	46.0	2.0	0.314	44.2	2.9	0.440	40.8	4.6	0.666	38.8	5.6	0.788	36.2	6.9	0.936
63	59.0	2.0	0.399	58.0	2.5	0.494	55.8	3.6	0.688	51.4	5.8	1.050	48.8	7.1	1.260	45.8	8.6	1.470
75	70.4	2.3	0.551	69.2	2.9	0.675	66.4	4.3	0.976	61.4	6.8	1.470	58.2	8.4	1.760	54.4	10.3	2.090
90	84.4	2.8	0.791	83.0	3.5	0.978	79.8	5.1	1.390	73.6	8.2	2.120	69.8	10.1	2.540	65.4	12.3	3.000
110	103.2	3.4	1.170	101.6	4.2	1.430	97.4	6.3	2.080	90.0	10.0	3.140	85.4	12.3	3.780	79.8	15.1	4.490
125	117.2	3.9	1.510	115.4	4.8	1.840	110.8	7.1	2.660	102.2	11.4	4.080	97.0	14.0	4.870	90.8	17.1	5.770
140	131.4	4.3	1.880	129.2	5.4	2.320	124.0	8.0	3.340	114.6	12.7	5.080	108.6	15.9	6.110	101.6	19.2	7.250
160	150.2	4.9	2.420	147.6	6.2	3.040	141.8	9.1	4.350	130.8	14.6	6.670	124.2	17.6	7.960	116.2	21.9	9.440
180	169.0	5.5	3.070	166.2	6.9	3.790	159.6	10.2	5.480	147.2	16.4	8.420	139.8	20.1	10.100	130.8	24.6	11.900
200	187.6	6.2	3.840	184.6	7.7	4.690	177.2	11.4	6.790	163.6	18.2	10.400	155.2	22.4	12.400	145.2	27.4	14.800
225	211.2	6.9	4.770	207.8	8.6	5.890	199.4	12.8	8.550	184.0	20.5	13.100	174.6	25.2	15.800	163.4	30.8	18.600
250	234.6	7.7	5.920	230.8	9.6	7.300	221.6	14.2	10.600	204.6	22.7	16.200	194.2	27.9	19.400	181.6	34.2	23.000
280	262.8	8.6	7.400	258.6	10.7	9.100	248.2	15.9	13.200	229.2	25.4	20.300	217.4	31.3	24.300	203.4	38.3	28.900
315	295.6	9.7	9.370	290.8	12.1	11.600	279.2	17.9	16.700	257.8	28.6	25.600	244.6	35.2	30.800	228.8	43.1	36.500
355	333.2	10.9	11.800	327.8	13.6	14.600	314.8	20.1	21.200	290.6	32.2	32.500	275.6	39.7	39.100	258.0	48.5	46.300
400	375.4	12.3	15.100	369.4	15.3	18.600	354.6	22.7	26.900	327.4	36.3	41.300	310.6	44.7	49.600	290.6	54.7	58.800
450	422.4	13.8	19.000	415.6	17.2	23.500	399.0	25.5	34.000	368.2	40.9	52.300	349.4	50.3	62.700	327.0	61.5	74.400
500	469.4	15.3	23.400	461.8	19.1	28.900	443.2	28.4	42.000	409.2	45.4	64.500	388.4	55.8	77.300	363.4	68.3	91.800
560	525.6	17.2	29.400	517.2	21.4	36.200	496.6	31.7	52.500	458.4	50.8	80.800	435.0	62.5	97.000	-	-	-
630	591.4	19.3	37.100	581.8	24.1	45.900	558.6	35.7	66.500	515.6	57.2	102.00	-	-	-	-	-	-
710	666.4	21.8	47.20	655.6	27.2	58.400	629.6	40.2	84.400	581.0	64.5	130.00						
800	751.0	24.5	59.70	738.8	30.6	73.900	709.4	45.3	107.00									
900	844.8	27.6	75.60	831.2	34.4	93.400	798.0	51.0	136.00									
1000	938.8	30.6	93.10	923.6	38.2	115.00	886.6	56.7	167.00									
1200	1126.6	36.7	134.00	1108.2	45.9	166.00	1064.0	68.0	241.00									

HDPE Perforated Pipe

PE80 Perorated all round pipes

Material

PE 80 acc. to DIN 8075, on request :
PE -EL polyethylene electrically conductive,
PP - H 100 acc. to DIN 8078

Dimensions

PE acc. to DIN 8074, PE acc. to DIN 8077
standard length 6 m. other lengths on request

Colour

PE black
PP grey

Design

Without runoff channel, perforated all round,
hole diameter 15 mm, non - perforated
pipe end min. 190 mm.

Special Designs

Diffrent hole diameters
(12 mm, 10 mm). perforation
arragement and perfortion separation
(30 mm) on request.

Remarks

In the case of a commission, verifiable anlyses
can be complied based on the ATV A 12.7 .
you will be invoiced for costs incurred. when
connecting with electro fusion sockets. only
the non-perforated area of the pipe should be used.

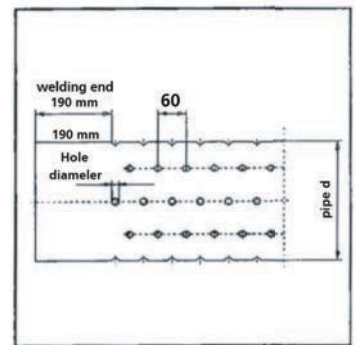
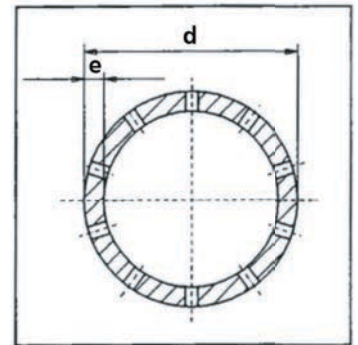

D MM	HOLE ROWS	ENTRY AREA F 1 CM ² / M	E MM	ENTRY AREA F2 %	E MM	ENTRY AREA F2 %
90	6	177	5.1	7.50	8.2	7.64
110	6	177	6.3	5.78	10.2	6.25
125	6	177	7.1	5.08	11.4	5.50
143	6	177	8.0	4.54	12.7	4.90
160	8	236	9.1	5.29	14.6	5.73
180	8	236	10.2	4.70	16.4	5.10
200	8	236	11.4	4.23	18.2	4.58
225	8	236	12.8	3.67	20.5	4.08
250	8	236	14.2	3.38	22.7	3.67
280	8	236	15.9	3.02	25.4	3.28
315	8	236	17.9	2.69	28.6	2.91
355	8	236	20.1	2.38	32.2	2.58
400	8	236	22.7	2.12	36.3	2.29
450	10	295	25.5	2.35	40.9	2.55
500	10	295	28.4	2.11	45.4	2.29
560	12	353	31.7	2.27	50.8	2.46
630	12	353	35.7	2.01	57.2	2.18

f1 = free entry area (cm²/m), relative to pipe inside surface area
f2 = free entry area (%), relative to pipe inside surface area

HDPE Slotted Pipe

PE80 Slotted all round Pipes

Material

PE 80 acc. to DIN 8075, on request :
PE -EL polyethylene electrically conductive,
PP - H 100 acc. to DIN 8078

Special Designs

Diffrent milling widths
(6mm, 8 mm or 10mm)
on request.

Dimensions

PE acc. to DIN 8074, PP acc. to DIN 8077
standard length 6 m. other lengths on request

Colour

PE black
PP grey

Design

Without runoff channel, slotted all round. milling
with $w = 12\text{mm}$, slot separation $a = 140\text{mm}$.
non-slotted pipe end pipe end min. 190 mm.

Remarks

In the case of a commission, verifiable anlyses
can be complied based on the ATV A 12.7 .
you will be invoiced for costs incurred. when
connecting with electro fusion sockets. only
the non-perforated area of the pipe should be used.

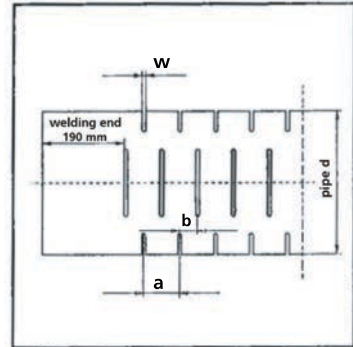
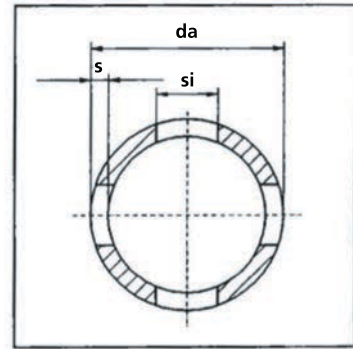

Pipe d mm	Slot length Interior mm	Entry area f_1 cm ² /m	SDR 17,6		SDR 11	
			e mm	Entry area f_2 %	e mm	Entry area f_2 %
180	80	199	10.2	4.0	16.4	4.3
200	80	199	11.4	3.6	18.2	3.9
225	80	199	12.8	3.2	20.5	3.4
250	80	199	14.2	2.9	22.7	3.1
280	80	199	15.9	2.6	25.4	2.8
315	80	199	17.9	2.3	28.6	2.5
355	80	199	20.1	2.0	32.2	2.2
400	80	199	22.7	1.8	36.3	1.9
450	80	199	25.5	1.6	40.9	1.7
500	80	199	28.4	1.4	45.4	1.6
560	80	199	31.7	1.3	50.8	1.4
630	80	199	35.7	1.1	57.2	1.2

f_1 = free entry area (cm²/m), relative to pipe inside surface area
 f_2 = free entry area (%), relative to pipe inside surface area

Transportation, Packaging, Handling and Storage of PE100 Pipes

Pipes

On trucks the 6m or longer pipes must be fully supported on the loading area. Avoid loading at the same time with sharp objects. Pipes should not be thrown or dragged along the ground.

Pipes should be given adequate support at all times. Pipes should not be stacked in large piles, especially in warm temperature conditions as the lower layers may distort, resulting in difficulties in jointing and pipe alignment. Any pipe with ends prepared for jointing (sockets and spigot joints, A joints, etc.) should be stacked in layers with sockets placed at alternate ends of the stacks and with the sockets protruding to avoid unstable stacks and the possibility of imparting a permanent set to the pipes.

For long-term storage, pipe racks should provide continuous support, but if this isn't possible timber of at least 3 in. (75mm) bearing width at spacing no greater than 3 ft. (915mm) centers for pipe sizes 160mm and above, should be placed beneath the pipes and at 6 ft. (1.8m) centers at the side, if the stacks are rectangular. These spacing apply to pipe size 160mm and above. Closer support will be required for size below 160mm in such pipe racks. Pipes may be stored not more than seven layers, or 6 ft. (1.8m) height, whichever is the lesser. But if different classes of pipe are kept in the same racks, than the thickness classes of the largest diameter must always be placed at bottom.

When loading pipes on to vehicles, care must be taken to avoid their coming into contact with any sharp corners such as cope irons, loose nail-heads, etc. as pipes may be damaged by being rubbed against these during transit. Whilst in transit pipes shall be well secured over their entire length and not allowed to project unsecured over the tailboard of the lorry pipes may off-loaded from lorries by rolling them gently down timbers, care being taken to ensure that pipes don't fall one upon another, nor on to any hard or uneven surfaces.

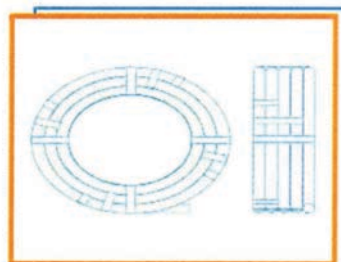

High Density Polyethylene Pipes

Flange Adaptor (Stub End)	19
Steel Flange PN 10	20
Steel Flange PN 16	21
Steel Flange & End cap	22
Tee & Tee & Reducer	23
Reducer & 90 Elbow	24

Flange adaptor (stub End)

Butt Welding - injection molded fitting > short spigot Code : WS - BWISE - 100 - (fitting size)

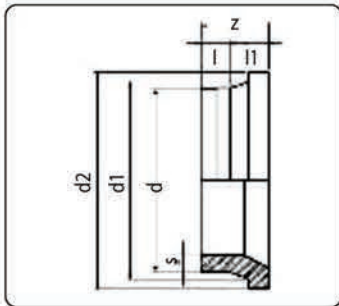

PE 100, PN 16, SDR11, S5

Item code	d mm	d1 mm	d2 mm	l mm	l1 mm	z mm	Thickness mm	Wieght kg
WS-BWISE -S100-355-11	355	376	430	164	40	243	32.2	9.050
WS-BWISE -S100-400-11	400	430	480	55	46	259	36.3	11.920
WS-BWISE -S100-450-11	450	517	585	50	46	120	40.9	8.330
WS-BWISE -S100-500-11	500	533	585	50	46	120	45.4	7.750
WS-BWISE -S100-560-11	560	618	685	50	50	130	50.8	10.900
WS-BWISE -S100-630-11	630	645	685	50	50	120	57.2	10.460
WS-BWISE -S100-710-11	710	740	800	50	60	140	64.5	15.470
WS-BWISE -S100-800-11	800	843	900	50	60	140	72.7	20.120
WS-BWISE -S100-900-11	900	947	1000	50	65	155	81.8	26.240
WS-BWISE -S100-1000-11	1000	1050	1113	50	70	170	90.9	36.280
WS-BWISE -S100-1100-11	1100							
WS-BWISE -S100-1200-11	1200							

l, Z diameter can be change as per the customer request ,for fabricated flange adaptor only

Flange adaptor (stub End)

Butt Welding - injection molded fitting > Long spigot Code : WS - BWISE - 100 - (fitting size)

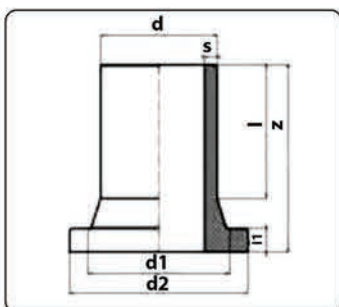

PE 100, PN 16, SDR11, S5

Item code	d mm	d1 mm	d2 mm	l mm	l1 mm	z mm	s mm	Wieght kg
WS-BWISE -L100-50-11	50	58	88	55	12	92	4.6	0.125
WS-BWISE -L100-63-11	53	78	102	63	14	100	5.8	0.190
WS-BWISE -L100-75-11	75	90	122	70	16	120	6.8	0.300
WS-BWISE -L100-90-11	90	108	138	79	17	132	8.2	0.455
WS-BWISE -L100-110-11	110	128	158	82	18	157	10	0.690
WS-BWISE -L100-125-11	125	135	158	87	25	170	11.4	0.880
WS-BWISE -L100-140-11	140	158	188	90	25	175	12.7	1.320
WS-BWISE -L100-160-11	160	178	212	98	25	180	14.6	1.630
WS-BWISE -L100-180-11	180	188	212	105	30	190	16.4	2.020
WS-BWISE -L100-200-11	200	235	268	112	32	200	18.2	2.680
WS-BWISE -L100-225-11	225	238	268	120	32	200	20.5	3.150
WS-BWISE -L100-250-11	250	288	320	128	35	205	22.7	4.030
WS-BWISE -L100-280-11	280	294	320	139	35	215	25.4	4.750
WS-BWISE -L100-315-11	315	338	370	150	35	220	28.6	6.650

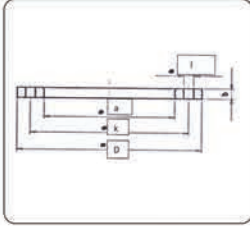

Steel FLANGES

item code	d mm	D (mm)	a (mm)	K (mm)	l (mm)	Ds
WS-CSSF	20	95	28	65	14	4
WS-CSSF	25	105	34	75	14	4
WS-CSSF	32	115	42	85	14	4
WS-CSSF	40	140	51	100	18	4
WS-CSSF	50	150	62	110	18	4
WS-CSSF	63	165	78	125	18	4
WS-CSSF	75	185	92	145	18	4
WS-CSSF	90	200	108	160	18	8
WS-CSSF	110	220	128	180	18	8
WS-CSSF	125	220	135	180	18	8
WS-CSSF	140	250	158	210	18	8
WS-CSSF	160	285	178	240	23	8
WS-CSSF	180	285	188	240	23	8
WS-CSSF	200	340	235	295	23	12
WS-CSSF	225	340	238	295	23	12
WS-CSSF	250	405	288	355	26	12
WS-CSSF	280	405	294	355	26	12
WS-CSSF	315	465	338	410	26	12
WS-CSSF	355	520	376	470	26	16
WS-CSSF	400	580	430	525	30	16
WS-CSSF	450	715	517	650	33	20
WS-CSSF	500	715	533	650	33	20
WS-CSSF	560	840	618	770	36	20
WS-CSSF	630	840	645	770	36	20
WS-CSSF	710	910	740	840	39	24
WS-CSSF	800	1025	843	950	39	24
WS-CSSF	900	1125	947	1050	39	28
WS-CSSF	1000	1255	1050	1170	42	28
WS-CSSF	1200	1485	1260	1390	48	32

Steel Flange

Polypropylene (PP) Coated

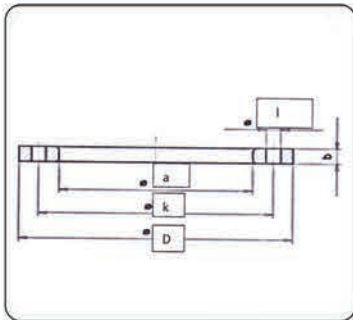

PP, ST, PN 16

Item code	d mm	D mm	a mm	k mm	b mm	l mm	Bolt size mm	No. of Holes
WS-PPSF -100-110-11	110	224	128	180	20	18	M 16	8
WS-PPSF -100-125-11	125	224	135	180	20	18	M16	8
WS-PPSF -100-140-11	140	252	158	210	24	18	M16	8
WS-PPSF -100-160-11	160	285	178	240	24	22	M20	8
WS-PPSF -100-180-11	180	285	188	240	24	22	M20	8
WS-PPSF -100-200-11	200	340	235	294	27	22	M20	12
WS-PPSF -100-225-11	225	340	238	294	27	22	M20	12
WS-PPSF -100-250-11	250	419	288	355	32	26	M24	12
WS-PPSF -100-280-11	280	419	294	355	32	26	M24	12
WS-PPSF -100-315-11	315	478	338	410	34	26	M24	12
WS-PPSF -100-355-11	355	532	376	470	42	26	M24	16
WS-PPSF -100-400-11	400	592	430	525	46	30	M27	16

PP, ST, PN 16

Item code	d mm	D mm	a mm	k mm	b mm	l mm	Bolt size mm	No. of Holes
WS-PPSF-100-450-11	450	715	517	650	45	33	M 30	20
WS-PPSF-100-500-11	500	715	533	650	45	33	M 30	20
WS-PPSF-100-560-11	560	840	618	770	50	36	M33	20
WS-PPSF-100-630-11	630	840	645	770	50	36	M33	20

End Cap

Butt welding - injection Modeled fitting Code : WS-BWIEC - 100 -(Fitting Size)

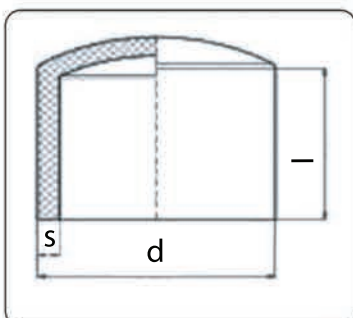

PE 100, PN16, SDR11, S5

Item code	d mm	l mm	s mm	Weight kg
WS-BWIEC -100-50-11	50	57	64	0.048
WS-BWIEC -100-63-11	63	65	5.8	0.084
WS-BWIEC -100-75-11	75	72	6.8	0.131
WS-BWIEC -100-90-11	90	81	8.2	0.218
WS-BWIEC -100-110-11	110	86	10	0.333
WS-BWIEC -100-125-11	125	93	11.4	0.485
WS-BWIEC -100-140-11	140	97	12.7	0.674
WS-BWIEC -100-160-11	160	103	14.6	0.953
WS-BWIEC -100-180-11	180	110	16.4	1.330
WS-BWIEC -100-200-11	200	117	18.2	1.760
WS-BWIEC -100-225-11	225	125	20.5	2.440
WS-BWIEC -100-250-11	250	136	22.7	3.660
WS-BWIEC -100-280-11	280	145	25.4	4.460
WS-BWIEC -100-315-11	315	155	28.6	6.170

Tee

Butt welding - injection Modeled fitting Code : WS -BWIT - 100 -(Fitting Size)

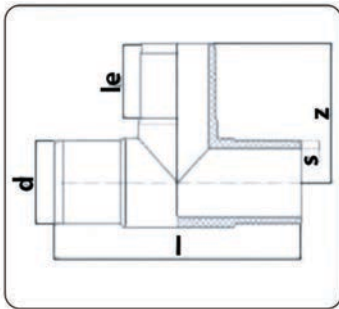

PE 100, PN16, SDR11, S5

Item code	d mm	l mm	le mm	z mm	s mm	Weight kg
WS-BWIT -100-50-11	50	230	57	114	4.6	0.232
ws-BWIT -100-63-11	63	230	65	115	5.8	0.370
ws-BWIT -100-75-11	75	264	72	132	6.8	0.550
ws-BWIT -100-90-11	90	301	81	150	8.2	0.900
ws-BWIT -100-110-11	110	330	86	165	10	1.480
ws-BWIT -100-125-11	125	366	93	183	11.4	2.200
ws-BWIT -100-140-11	140	380	97	190	12.7	3.020
ws-BWIT -100-160-11	160	420	103	210	14.6	3.890
ws-BWIT -100-180-11	180	460	110	230	16.4	5.770
ws-BWIT -100-200-11	200	500	117	250	18.2	7.460
ws-BWIT -100-225-11	225	540	125	270	20.5	10.700
ws-BWIT -100-250-11	250	620	135	312	22.7	14.040
ws-BWIT -100-280-11	280	690	145	346	25.4	21.880
ws-BWIT -100-315-11	315	748	155	375	28.6	28.770

Tee - Reducer

Butt welding - injection Modeled fitting Code : WS -BWITR - 100 -(Fitting Size)

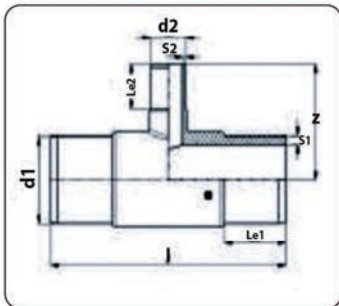

PE 100, PN16, SDR11, S5

Item code	d1-d2 mm	l mm	le1 mm	le2 mm	z mm	s1 mm	s2 mm	Weight kg
WS-BWITR -100-63x50-11	63-50	230	65	57	108	5.8	4.6	0.340
WS-BWITR -100-75x50-11	76-50	264	72	57	117	6.8	4.6	0.508
WS-BWITR -100-75x63-11	75-50	264	72	65	125	6.8	5.8	0.518
WS-BWITR -100-90x63-11	90x63	301	81	65	134	8.2	5.8	0.810
WS-BWITR -100-90x75-11	90x75	301	81	72	141	8.2	6.8	0.840
WS-BWITR -100-110x63-11	110x63	330	86	65	144	10	5.8	1.246
WS-BWITR -100-110x75-11	110x75	330	86	62	151	10	6.8	1.290
WS-BWITR -100-125x90-11	125x90	366	93	81	167	11.4	8.2	1.980
WS-BWITR -100-125x110-11	125x110	366	93	86	176	11.4	10	2.090
WS-BWITR -100-160x110-11	160x110	420	103	76	193	14.6	10	3.290
WS-BWITR -100-200x160-11	200x160	500	117	103	243	18.2	14.5	6.247
WS-BWITR -100-225x160-11	225x160	540	125	103	263	20.5	14.5	8.383
WS-BWITR -100-250x160-11	250x160							
WS-BWITR -100-225x110-11	225x110							
WS-BWITR -100-225x160-11	225x160							
WS-BWITR -100-280x160-11	280x160							
WS-BWITR -100-280x200-11	280x200							
WS-BWITR -100-280x250-11	280x250							
WS-BWITR -100-315x110-11	315x110							
WS-BWITR -100-315x160-11	315x160							
WS-BWITR -100-315x250-11	315x250							

Reducer

Butt welding - injection Modeled fitting Code : WS - BWIR - 100 -(Fitting Size)

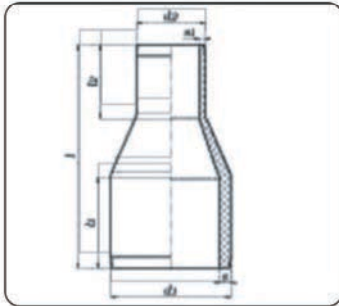

PE 100, PN16, SDR11, S5

Item code	d1-d2 mm	l mm	l1 mm	l2 mm	s1 mm	s2 mm	Weight kg
WS-BWIR -100-63x25-11	63-25	150	65	52	5.8	3	0.100
WS-BWIR -100-90x50-11	90-50	190	81	63	8.2	4.6	0.292
WS-BWIR -100-60x63-11	90-63	190	81	65	8.2	5.8	0.320
WS-BWIR -100-90x75-11	90-75	190	81	70	8.2	6.8	0.360
WS-BWIR -100-110x63-11	110-63	205	86	65	10	5.8	0.470
WS-BWIR -100-110x75-11	110-75	205	86	70	10	6.8	0.520
WS-BWIR -100-110x90-11	110-90	205	86	81	10	8.2	0.593
WS-BWIR -100-125x63-11	125-63	215	92	65	11.4	5.8	0.530
WS-BWIR -100-125x75-11	125-75	215	92	70	11.4	6.8	0.650
WS-BWIR -100-125x90-11	125-90	215	92	81	11.4	8.2	0.680
WS-BWIR -100-125x110-11	125-110	215	92	86	11.4	6.8	0.760
WS-BWIR -100-140x110-11	140-110	225	96	86	12.7	8.2	1.020
WS-BWIR -100-140x125-11	140-125	225	96	92	12.7	10	1.130
WS-BWIR -100-160x90-11	160x90	245	102	81	14.6	10	1.180
WS-BWIR -100-160x110-11	160x110	245	102	86	14.6	11.4	1.320
WS-BWIR -100-160x125-11	160x125	245	102	92	18.2	8.2	1.440
WS-BWIR -100-200x160-11	200x160	275	120	102	20.5	10	2.580
WS-BWIR -100-225x160-11	225x160	285	128	102	20.5	11.4	3.100
WS-BWIR -100-225x200-11	225x200	285	128	120	22.7	14.6	3.680
WS-BWIR -100-250x160-11	50x160	314	155	102	22.7	14.6	2.680
WS-BWIR -100-250x200-11	250x200	314	155	120	22.7	18.2	3.120
WS-BWIR -100-250x225-11	250x225	293	155	128	22.7	20.5	3.210
WS-BWIR -100-315x225-11	315x225	435	170	128	28.6	20.5	3.330
WS-BWIR -100-315x250-11	315x250	390	170	155	28.6	22.7	6.105

90 Elbow

Butt welding - injection Modeled fittings Code : WS - BWIE90- 100-(Fitting Size)

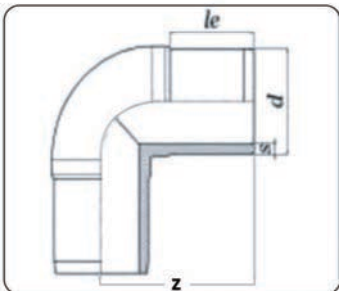

PE 100, PN16, SDR11, S5

Item code	d1-d2 mm	l mm	le1 mm	le2 mm	z mm	s1 mm	s2 mm	Weight kg
WS-BWIE90-100-63-11	63	63	118		5.8			0.274
WS-BWIE90-100-75-11	75	70	133		6.8			0.420
WS-BWIE90-100-90-11	90	81	150		8.2			0.658
WS-BWIE90-100-110-11	110	86	165		10			1.153
WS-BWIE90-100-125-11	125	9	180		11.4			1.540
WS-BWIE90-100-140-11	140	97	190		12.7			2.160
WS-BWIE90-100-160-11	160	103	210		14.6			2.920
WS-BWIE90-100-180-11	180	110	232		16.4			3.900
WS-BWIE90-100-180-11	200	117	253		18.2			5.530
WS-BWIE90-100-225-11	225	125	270		20.5			7.440
WS-BWIE90-100-250-11	250	135	307		22.7			9.860
WS-BWIE90-100-280-11	280	145	340		25.4			13.520
WS-BWIE90-100-315-11	315	155	370		28.6			20.600

Butt Welding- Fabricated Fittings

90 Elbow	24
45 Elbow	25
Tee - PE 100 & PE80	25
Tee - Reducer (MKM)	26
Tee - Reducer (MKM)	27
Tee - Reducer (MKM)	28
Tee - Reducer (MKM)	29

90° Elbow

Butt welding - fabricated Modeled fittings Code : BWFE 90 - 100 - (Fitting Size)

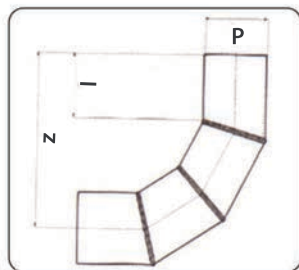

PE 100, PN16

Item code	d mm	i mm	z mm
WS-BWFE90-100-140-11	140	92	374
WS-BWFE90-100-180-11	180	105	407
WS-BWFE90-100-225-11	225	120	445
WS-BWFE90-100-250-11	250	129	466
WS-BWFE90-100-280-11	280	139	491
WS-BWFE90-100-315-11	315	150	520
WS-BWFE90-100-355-11	355	164	554
WS-BWFE90-100-400-11	400	173	591
WS-BWFE90-100-450-11	450	195	632
WS-BWFE90-100-500-11	500	212	974
WS-BWFE90-100-560-11	560	235	727
WS-BWFE90-100-630-11	630	255	782
WS-BWFE90-100-710-11	710	255	822
WS-BWFE90-100-800-11	800	255	867
WS-BWFE90-100-900-11	900		
WS-BWFE90-100-1000-11	1000		
WS-BWFE90-100-1100-11	1100		
WS-BWFE90-100-1200-11	1200		

45° Elbow

Butt welding - fabricated Modeled fittings Code : WS -BWFE45 - 100-(Fitting Size)

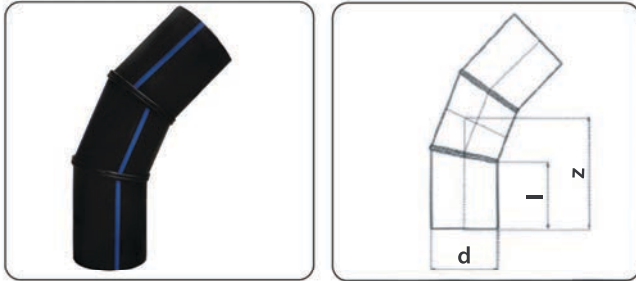

PE 100, PN16

Item code	d mm	l mm	z mm
WS -BWFE45 -100-125-11	125	87	185
WS -BWFE45-100-140-11	140	92	192
WS -BWFE45-100-160-11	160	98	200
WS -BWFE45-100-180-11	180	105	210
WS -BWFE45-100-200-11	200	112	220
WS -BWFE45-100-225-11	225	120	231
WS -BWFE45-100-250-11	250	129	243
WS -BWFE45-100-280-11	280	139	257
WS -BWFE45 -100-315-11	315	150	273
WS -BWFE45-100-355-11	355	164	319
WSBWFE45-100-400-11	400	179	339
WS -BWFE45-100-450-11	450	195	362
WS -BWFE45-100-500-11	500	212	422
WS -BWFE45-100-560-11	560	235	442
WS -BWFE45-100-630-11	630	255	471
WS -BWFE45-100-710-11	710	255	505
WS -BWFE45-100-800-11	800	255	513
WS -BWFE45-100-900-11	900		
WS -BWFE45-100-1000-11	1000		
WS -BWFE45-100-1100-11	1100		
WS -BWFE45-100-1200-11	1200		

TEE PE 100 & PE 80

(WS-BWFT) TEE PE 100 & PE 80

SDR 11

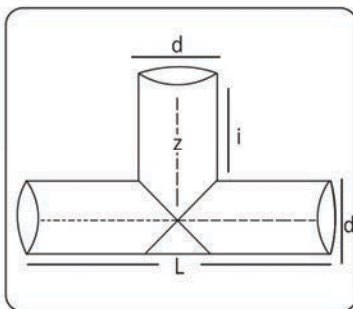

Item code	OD mm	L mm	l mm	Z mm
WS-BWFT-100-110 -11	110	165	150	210
WS-BWFT-100-125 -11	125	313	150	220
WS-BWFT-100-160 -11	160	460	150	230
WS-BWFT-100-180 -11	180	480	150	240
WS-BWFT-100-200 -11	200	500	150	250
WS-BWFT-100-225 -11	225	530	150	265
WS-BWFT-100-250 -11	250	750	250	375
WS-BWFT-100-280 -11	280	780	250	390
WS-BWFT-100-315 -11	315	920	300	460
WS-BWFT-100-355 -11	355	960	300	480
WS-BWFT-100-400 -11	400	1000	300	500
WS-BWFT-100-450 -11	450	1050	300	525
WS-BWFT-100-500 -11	500	1200	350	600
WS-BWFT-100-560 -11	560	1260	350	630
WS-BWFT-100-630 -11	630	1330	350	665
WS-BWFT-100-710 -11	710	1410	350	705
WS-BWFT-100-800 -11	800	1500	350	750
WS-BWFT-100-900 -11	900	1700	400	850
WS-BWFT-100-1000-11	1000	2040	520	1020
WS-BWFT-100-1100-11	1100	2270	540	1135
WS-BWFT-100-1200-11	1200	2500	650	1250

Tee - Reducer (MKM)

Butt welding - fabricated Modeled fittings Code : WS -BWFTR - 100 - (Fitting Size)

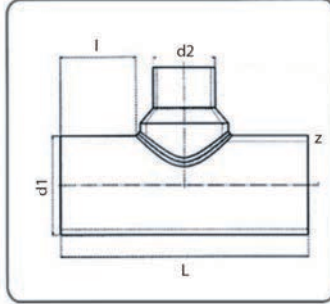

PE 100, PN16, SDR11, S5

Item Code	d1 mm	d2 mm	l mm	z mm	L mm
WS-BWFTR-100-160X63-11	160	63	98	173	321
WS-BWFTR-100-160X90-11	160	90	98	189	321
WS-BWFTR-100-160X110-11	160	110	98	192	321
WS-BWFTR-100-160X125-11	160	125	98	197	336
WS-BWFTR-100-180X63-11	180	63	105	183	335
WS-BWFTR-100-180X90-11	180	90	105	199	335
WS-BWFTR-100-180X110-11	180	110	105	202	335
WS-BWFTR-100-180X125-11	180	125	105	207	350
WS-BWFTR-100-180X160-11	180	160	105	218	370
WS-BWFTR-100-200X63-11	200	63	112	193	349
WS-BWFTR-100-200X90-11	200	90	112	209	349
WS-BWFTR-100-200X110-11	200	110	112	212	384
WS-BWFTR-100-200X125-11	200	125	112	217	384
WS-BWFTR-100-200X160-11	200	160	112	228	404
WS-BWFTR-100-225X90-11	225	90	120	222	365
WS-BWFTR-100-225X110-11	225	110	120	225	400
WS-BWFTR-100-225X125-11	225	125	120	230	400
WS-BWFTR-100-225X160-11	225	160	120	241	420
WS-BWFTR-100-250X63-11	250	63	129	218	383
WS-BWFTR-100-250X90-11	250	90	129	234	383
WS-BWFTR-100-250X110-11	250	110	129	237	418
WS-BWFTR-100-250X125-11	250	125	129	242	418
WS-BWFTR-100-250X160-11	250	160	129	253	438
WS-BWFTR-100-250X200-11	250	200	129	267	483
WS-BWFTR-100-280X63-11	280	63	139	233	403
WS-BWFTR-100-280X90-11	280	90	139	249	403
WS-BWFTR-100-280X110-11	280	110	139	252	418
WS-BWFTR-100-280X125-11	280	125	139	257	458
WS-BWFTR-100-280X160-11	280	160	139	268	458
WS-BWFTR-100-280X200-11	280	200	139	282	503
WS-BWFTR-100-315X63-11	315	63	150	251	480
WS-BWFTR-100-315X90-11	315	90	150	267	480
WS-BWFTR-100-315X110-11	315	110	150	270	480
WS-BWFTR-100-315X125-11	315	125	150	275	480
WS-BWFTR-100-315X160-11	315	160	150	286	480

Item Code	d1 mm	d2 mm	l mm	z mm	L mm
WS-BWFTR-100-315X200-11	315	200	150	300	525
WS-BWFTR-100-315X250-11	315	250	150	317	580
WS-BWFTR-100-355X63-11	355	63	164	271	508
WS-BWFTR-100-355X90-11	355	90	164	287	508
WS-BWFTR-100-355X110-11	355	110	164	290	508
WS-BWFTR-100-355X125-11	355	125	164	295	508
WS-BWFTR-100-355X160-11	355	160	164	306	508
WS-BWFTR-100-355X200-11	355	200	164	320	553
WS-BWFTR-100-355X250-11	355	250	164	337	608
WS-BWFTR-100-400X63-11	400	63	179	293	538
WS-BWFTR-100-400X90-11	400	90	179	309	538
WS-BWFTR-100-400X110-11	400	110	179	312	538
WS-BWFTR-100-400X125-11	400	125	179	317	538
WS-BWFTR-100-400X160-11	400	160	179	328	538
WS-BWFTR-100-400X200-11	400	200	179	342	538
WS-BWFTR-100-400X250-11	400	250	179	359	638
WS-BWFTR-100-450X63-11	450	63	195	318	590
WS-BWFTR-100-450X90-11	450	90	195	334	590
WS-BWFTR-100-450X110-11	450	110	195	337	590
WS-BWFTR-100-450X125-11	450	125	195	342	590
WS-BWFTR-100-450X160-11	450	160	195	353	590
WS-BWFTR-100-450X200-11	450	200	195	367	615
WS-BWFTR-100-450X250-11	450	250	195	384	670
WS-BWFTR-100-500X63-11	500	63	212	343	624
WS-BWFTR-100-500X90-11	500	90	212	359	624
WS-BWFTR-100-500X110-11	500	110	212	362	624
WS-BWFTR-100-500X125-11	500	125	212	367	624
WS-BWFTR-100-500X160-11	500	160	212	378	624
WS-BWFTR-100-500X200-11	500	200	212	392	624
WS-BWFTR-100-500X250-11	500	250	212	409	624
WS-BWFTR-100-560X63-11	560	63	235	373	670
WS-BWFTR-100-560X90-11	560	90	235	389	670
WS-BWFTR-100-560X110-11	560	110	235	392	670
WS-BWFTR-100-560X125-11	560	125	235	397	670
WS-BWFTR-100-560X160-11	560	160	235	408	670
WS-BWFTR-100-560X180-11	560	180	235	415	670
WS-BWFTR-100-560X200-11	560	200	235	422	670
WS-BWFTR-100-630X90-11	630	90	255	424	735
WS-BWFTR-100-630X110-11	630	110	255	427	735
WS-BWFTR-100-630X125-11	630	125	255	432	735
WS-BWFTR-100-630X160-11	630	160	255	443	735
WS-BWFTR-100-630X200-11	630	200	255	457	760

Tee - Reducer (MKM)

Butt welding - fabricated fittings Code : WS -BWfTR - 100 - (Fitting Size)

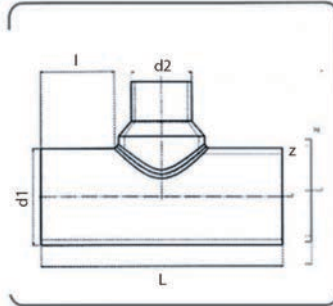

PE 100, PN16, SDR11, S5

Item Code	d1 mm	d2 mm	l mm	z mm	L mm
WS-BWFTR-100-630X250-11	630	250	255	474	825
WS-BWFTR-100-630X280-11	630	280	255	484	825
WS-BWFTR-100-630X315-11	630	315	255	495	865
WS-BWFTR-100-630X355-11	630	355	255	509	910
WS-BWFTR-100-630X400-11	630	400	255	524	960
WS-BWFTR-100-630X450-11	630	450	255	540	1010
WS-BWFTR-100-630X500-11	630	500	255	557	1070
WS-BWFTR-100-630X560-11	630	560	255	580	1070
WS-BWFTR-100-710X90-11	710	90	255	464	735
WS-BWFTR-100-710X110-11	710	110	255	467	735
WS-BWFTR-100-710X125-11	710	125	255	472	735
WS-BWFTR-100-710X140-11	710	140	255	477	735
WS-BWFTR-100-710X160-11	710	160	255	483	735
WS-BWFTR-100-710X180-11	710	180	255	490	735
WS-BWFTR-100-710X200-11	710	200	255	497	760
WS-BWFTR-100-710X225-11	710	225	255	505	790
WS-BWFTR-100-710X250-11	710	250	255	514	825
WS-BWFTR-100-710X280-11	710	280	255	524	865
WS-BWFTR-100-710X315-11	710	315	255	535	910
WS-BWFTR-100-710X355-11	710	355	255	549	960
WS-BWFTR-100-710X400-11	710	400	255	564	1010
WS-BWFTR-100-710X450-11	710	450	255	580	1070
WS-BWFTR-100-710X500-11	710	500	255	597	1140
WS-BWFTR-100-710X560-11	710	560	255	620	1140
WS-BWFTR-100-710X630-11	710	630	255	640	1140
WS-BWFTR-100-800X90-11	800	90	255	509	735
WS-BWFTR-100-800X110-11	800	110	255	512	735
WS-BWFTR-100-800X125-11	800	125	255	517	735
WS-BWFTR-100-800X140-11	800	140	255	522	735
WS-BWFTR-100-800X160-11	800	160	255	528	735
WS-BWFTR-100-800X180-11	800	180	255	535	735
WS-BWFTR-100-800X200-11	800	200	255	542	790
WS-BWFTR-100-800X225-11	800	225	255	550	825
WS-BWFTR-100-800X250-11	800	250	255	559	825
WS-BWFTR-100-800X280-11	800	280	255	569	865

Item Code	d1 mm	d2 mm	l mm	z mm	L mm
WS-BWFTR-100-800X315-11	800	315	255	580	910
WS-BWFTR-100-800X355-11	800	355	255	594	910
WS-BWFTR-100-800X400-11	800	400	255	609	960
WS-BWFTR-100-800X450-11	800	450	255	625	1010
WS-BWFTR-100-800X500-11	800	500	255	642	1070
WS-BWFTR-100-800X560-11	800	560	255	665	1140
WS-BWFTR-100-800X630-11	800	630	255	685	1220
WS-BWFTR-100-800X710-11	800	710	255	685	1220
WS-BWFTR-100-900X110-11	900	110			
WS-BWFTR-100-900X125-11	900	125			
WS-BWFTR-100-900X140-11	900	140			
WS-BWFTR-100-900X160-11	900	160			
WS-BWFTR-100-900X180-11	900	180			
WS-BWFTR-100-900X200-11	900	200			
WS-BWFTR-100-900X225-11	900	225			
WS-BWFTR-100-900X250-11	900	250			
WS-BWFTR-100-900X280-11	900	280			
WS-BWFTR-100-900X315-11	900	315			
WS-BWFTR-100-900X355-11	900	355			
WS-BWFTR-100-900X400-11	900	400			
WS-BWFTR-100-900X450-11	900	450			
WS-BWFTR-100-900X500-11	900	500			
WS-BWFTR-100-900X560-11	900	560			
WS-BWFTR-100-900X630-11	900	630			
WS-BWFTR-100-900X900-11	900	800			
WS-BWFTR-100-1000X140-11	1000	140			
WS-BWFTR-100-1000X160-11	1000	160			
WS-BWFTR-100-1000X180-11	1000	180			
WS-BWFTR-100-1000X200-11	1000	200			
WS-BWFTR-100-1000X225-11	1000	225			
WS-BWFTR-100-1000X250-11	1000	250			
WS-BWFTR-100-1000X280-11	1000	280			
WS-BWFTR-100-1000X315-11	1000	315			
WS-BWFTR-100-1000X355-11	1000	355			
WS-BWFTR-100-1000X400-11	1000	400			
WS-BWFTR-100-1000X450-11	1000	450			
WS-BWFTR-100-1000X500-11	1000	500			
WS-BWFTR-100-1000X560-11	1000	560			
WS-BWFTR-100-1000X630-11	1000	630			
WS-BWFTR-100-1000X800-11	1000	800			

Tee - Reducer (MKM)

Butt welding - fabricated fittings Code : WS -BWFTR - 100 - (Fitting Size)

PE 100, PN16, SDR11, S5

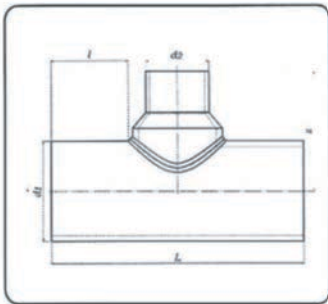

Item Code	d1 mm	d2 mm	l mm	z mm	L mm
WS-BWFTR-100-1100X125-11	1100	160			
WS-BWFTR-100-1100X180-11	1100	180			
WS-BWFTR-100-1100X200-11	1100	200			
WS-BWFTR-100-1100X225-11	1100	225			
WS-BWFTR-100-1100X250-11	1100	250			
WS-BWFTR-100-1100X280-11	1100	280			
WS-BWFTR-100-1100X315-11	1100	315			
WS-BWFTR-100-1100X355-11	1100	355			
WS-BWFTR-100-1100X400-11	1100	400			
WS-BWFTR-100-1100X450-11	1100	450			
WS-BWFTR-100-1100X500-11	1100	500			
WS-BWFTR-100-1100X560-11	1100	560			
WS-BWFTR-100-1100X630-11	1100	630			
WS-BWFTR-100-1100X710-11	1100	710			
WS-BWFTR-100-1100X800-11	1100	800			
WS-BWFTR-100-1100X900-11	1100	900			
WS-BWFTR-100-1100X1000-11	1100	1000			
WS-BWFTR-100-1200X180-11	1200	180			
WS-BWFTR-100-1200X200-11	1200	200			
WS-BWFTR-100-1200X225-11	1200	225			
WS-BWFTR-100-1200X250-11	1200	250			
WS-BWFTR-100-1200X280-11	1200	280			
WS-BWFTR-100-1200X315-11	1200	315			
WS-BWFTR-100-1200X355-11	1200	355			
WS-BWFTR-100-1200X400-11	1200	400			
WS-BWFTR-100-1200X450-11	1200	450			
WS-BWFTR-100-1200X500-11	1200	500			
WS-BWFTR-100-1200X560-11	1200	560			
WS-BWFTR-100-1200X630-11	1200	630			
WS-BWFTR-100-1200X710-11	1200	710			
WS-BWFTR-100-1200X800-11	1200	800			
WS-BWFTR-100-1200X900-11	1200	900			
WS-BWFTR-100-1200X1000-11	1200	1000			

Cross Tee

Butt welding - fabricated fittings Code : WS - BWFCT - 100 - (Fitting Size)

PE 100, PN16

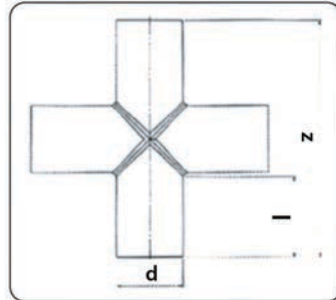

Item code	d mm	l mm	z mm
WS-BWFCT -100-110-16	110	82	294
WS-BWFCT -100-125-16	125	84	319
WS-BWFCT -100-140-16	140	92	344
WS-BWFCT -100-160-16	160	98	376
WS-BWFCT -100-180-16	180	105	410
WS-BWFCT -100-200-16	200	112	444
WS-BWFCT -100-225-16	225	120	485
WS-BWFCT -100-250-16	250	129	528

Item code	d mm	l mm	z mm
WS-BWFCT -100-280-16	280	139	578
WS-BWFCT -100-315-16	315	150	635
WS-BWFCT -100-355-16	355	164	703
WS-BWFCT -100-400-16	400	179	778
WS-BWFCT -100-450-16	450	195	860
WS-BWFCT -100-500-16	500	212	944
WS-BWFCT -100-560-16	560	235	1050
WS-BWFCT -100-630-16	630	255	1160

Butt Fusion Welding Machine

Hydraulic butt fusion welding machine delta dragon 250b	30
Butt fusion welding machine delta dragon 355b	31
Butt fusion welding machine delta 630	32
Basic line vs delta dragon differences (electro-hydraulic case)	33
Basic line vs delta dragon differences (machine body)	34
Basic easy life	35
Basic 160-200 & Basic 250 - 315	36-37
Welding General Criteria	38-46
Parts Description	47-53
Maintenance	54-56

HYDRAULIC BUTT FUSION WELDING MACHINE

Delta Dragon 250B



Technical Features	Delta Dragon 250B		Delta Dragon 315B
WORKING RANGE	250 + 75 MM		315 + 90 MM
POWER SUPPLY	110 V	230 V	230 V
	Single phase- 60 / 50 hz		Single phase- 60 / 50 hz
Total absorbed power	3470 w	3470 w	4420 w
Working Temperature	280 + 180 c		280 + 180 c
Ambient Temperature	-40 ++5 c		-40 ++5 c
Time to reach welding temperature	< 20 min		< 20 min
Materais	HDPE, PP, PB, PVDF		HDPE , PP, PB , PVDF

DIMENSIONS (W D H)		
Machine body	100 × 543 × 418 mm	1150 × 530 × 531 mm

WEIGHT		
Machine body		86.00 Kg
Total (Del ta Dragin 250 B only)	118.00 kg	160.00 Kg



Delta Dragon 315B

BUTT FUSION WELDING MACHINE

Delta Dragon 355B



Technical Features	Delta Dragon 355B	Delta Dragon 500
WORKING RANGE	355 + 125 MM	500 + 200 MM
POWER SUPPLY	230 V	230 V 400 V
	Single phase- 60 / 50 hz	Single phase- 60 / 50 hz
	180°C + 280°C	Single phase- 60 / 50 hz
Total absorbed power	500 W	7950 W 7200 W
Working Temperature	5800 w	280 + 180 c
Ambient Temperature	-40 ++5 c	-++5 40 c
Time to reach welding temperature	< 20 min	< 20 min
Materais	HDPE, PP, PB, PVDF	HDPE, PP, PB, PVDF
DIMENSIONS (W x D x H)		
Machine body	1208 x 725 x 584 mm	1330 x 840 x 845 mm
WEIGHT		
Machine body	157.0 Kg	197.00 Kg
Standard composition	269.00 kg	364.00 Kg

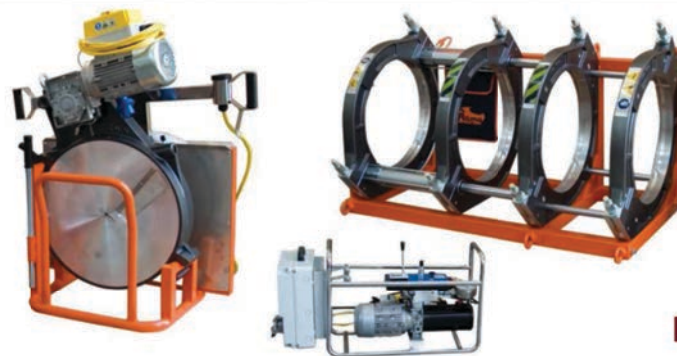

Delta 500

BUTT FUSION WELDING MACHINE



Technical Features	Delta 630
WORKING RANGE	280 + 630 MM
POWER SUPPLY	230 - 400V 3F +N+PE 50/60Hz
Max. absorbed power	12312 w
Working Temperature	180 + 280°c
Ambient Temperature	-5+ + 40°c
Time to reach welding temperature	< 35 min
Materais	HDPE, PP, PB , PVDF
DIMENSIONS (W x D x H)	
Machine body	1435 × 1010 × 1000 mm
WEIGHT	
Machine body	415 Kg
Standard composition	708 Kg



digital Dragon -
 temprature controller



Fast removing system

BASIC LINE *Professional*

DELTA DRAGON *Professional High Tech*

Differences (Electro-Hydraulic Case)



Rugged Plastic Case to Protect the hydraulic system against accidental drops, hits, dust and humidity.



Timer Mounted on case panel



Wider gripping areas on pipes and fitting

BASIC LINE *Professional*

DELTA DRAGON *Professional High Tech*

Differences (Machine Body)



Adjustable welding position to fit narrow and uncomforatble work fields



Large side handles for easier transport



Rollers available on machine body

BUTT FUSION WELDING MACHINE



BASIC EASY LIFE

Basic EASY LIFE is the new evolution of the BASIC range. Thanks to the special gearcase, the EASY LIFE system, can manage the welding process on a semi automatic way. The electronic system guarantees the continuous repeating of the welding cycles and automatically controls the preset parameters. The use of the EASY LIFE together with the INSPECTOR data logger guarantees certified welds comparable to those performed with a CNC automatic machine. Also the *Dual Pressure* welding method is made easy and reliable thanks to the Easy life gear case.

The EASY LIFE system is available for the complete BASIC range.

The EASY LIFE system is available of : an extractable box in plastic featuring, a control panel with push buttons for managing *Programming and process* welding pressure/time, an electric panel with a safety circuit breaker and overload cutout – power outlet, connection for the electronic data – logger Inspector, hydraulic hoses with non – drip fast couplings.

Technical Features

DIMENSIONS (W x D x H)	585 x 384 x 463 MM
Weight	37 Kg
POWER SUPPLY	230 V single phase 60/50 Hz
Total absorbed power	1100 w

BASIC EVOLUTION

BASIC EASY LIFE 160

BASIC EASY LIFE 200

BASIC EASY LIFE 250

BASIC EASY LIFE 315

BASIC EASY LIFE 355



BUTT FUSION WELDING MACHINE



BASIC 160 -200

Basic 200/160 is able to weld fittings such as elbows, tees, Y-branches and flange necks without any additional equipment by simply fixing the dampers' drag bar.

Basic 200/160 includes :

- A machine body with 4 clamps and 2 hydraulic with fast non-drip couplings.
- An extractable heating plate with DIGITAL DRAGON, high – precision electronic thermo – regulator.
- An extractable milling cutter, with safely micro – switch.
- An electro – hydraulic gearcase, with clamp opening and closing lever.
- An hydraulic hoses with non-drip quick couplings.

STANDARD COMPOSITON

Basic 160 adapters, from (...) 40 to 140 mm.

Basic 200 adapters, from (...) 63 to 180 mm.

ON REQUEST (ACCESSORIES)

Tool for necks (only BASIC 200) .

EASY LIFE GEARBOX.

BASIC 160

MATERIALS	HDPE - PB – PP - PVDF
WORKING RANGE	40 + 160 mm
POWER SUPPLY	230 VAC
Single phase	50/60 Hz
Total absorbed power	1900 W
Working Temperature	180 + 2t80°c
Pressure woring range	0 + 150 bar
Weight only body machines	30 kg

BASIC 200

MATERIALS	HDPE - PB – PP - PVDF
WORKING RANGE	63 + 200 mm
POWER SUPPLY	230 VAC
Single phase	50/60 Hz
Total absorbed power	3000 w
Working Temperature	180 + 280°c
Pressure woring range	0 + 150 bar
Weight only body machines	35 kg



BUTT FUSION WELDING MACHINE



BASIC 250

BASIC 315/250 is able to weld fitting such as elbows, tees Y – branches and flange necks without any additional equipment by simply fixing the clamps drag bar.

BASIC 315/250 includes :

- A machine body with 4 clamps and 2 hydraulic cylinders with fast non-drip couplings.
- An extractable heating plate with DIGITAL DRAGON, high – precision thermo – regulator.
- An electro – hydraulic gearcase, with a clamp opening and closing lever.
- A hydraulic hoses with non-drip quick couplings.

BASIC 250

MATERIALS	HDPE - PB – PP - PVDF
WORKING RANGE	75 + 250 MM
POWER SUPPLY	230 VAC
Single phase	50/60 Hz
Total absorbed power	3500 W
Working Temperature	180+280 c
Pressure woring range	0 + 150 bar
Weight only body machines	54 kg

STANDARD COMPOSITION

Adapters, from Ø 75 to 255 mm

ON REQUEST (ACCESSORIES)

Tool for flange necks.
EASY LIFE greabox



BASIC 315

BASIC 315

MATERIALS	HDPE - PB – PP - PVDF
WORKING RANGE	90 + 315 MM
POWER SUPPLY	230 VAC
Single phase	50/60 Hz
Total absorbed power	4500 w
Working Temperature	180+280 c
Pressure woring range	0 + 150 bar
Weight only body machines	86 kg

STANDARD COMPOSITION

Adapters, from Ø 90 to 280 mm
Master adapter Ø 250 mm

ON REQUEST (ACCESSORIES)

Tool for flange necks.
EASY LIFE greabox



2. WELDING GENERAL CRITERIA معايير اللحام العامة

يتطلب الانتباه التام عند نقل المواسير/التركيبات وتحميلها / تفرغها ومناولتها وتخزينها، ويجب أن يتم ذلك باستخدام الأجهزة الميكانيكية المناسبة.

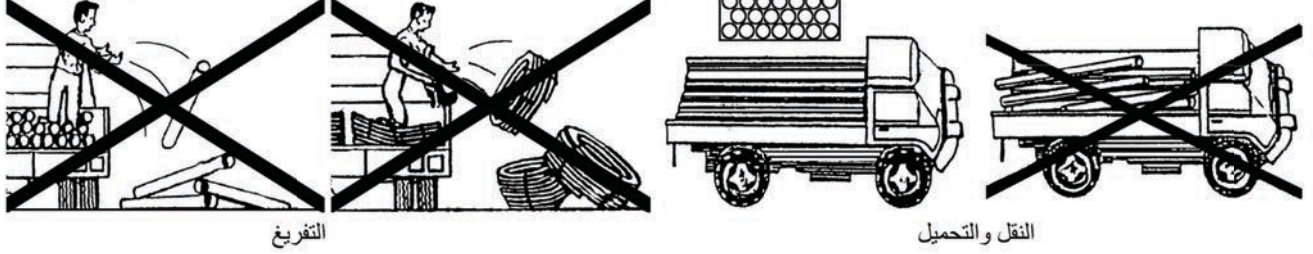

من المهم تجنب وجود الخدوش و/أو التحزيزات العميقة على المواسير/التركيبات. لا تجر المواسير/التركيبات على الأسطح الخشنة أو الحادة (مثل الألواح الجانبية بالشاحنة، أدوات العمل، التربة الصخرية، إلخ).

The transport, loading / unloading, handling and storage of the pipes/fittings require extreme attention, and must be done by means of suitable mechanical devices.

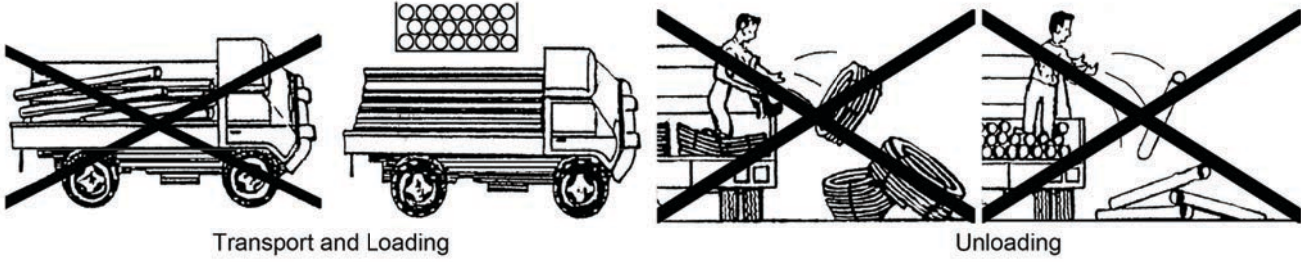

It is essential to avoid deep scratches and/or notches on the pipes/fittings. Do not drag the pipes/fittings on rough or sharp surfaces (such as truck side-boards, work tools, rocky soil, etc.).

قبل اللحام

أجهزة القياس:

تحقق من وظائفهم.

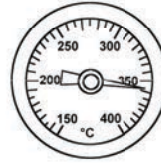

الترمومتر

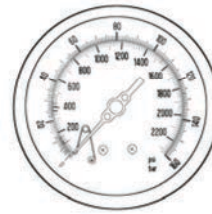

المانومتر



الموقت

تحقق من وظيفتها.

تأكد من أن الشفرات حادة بدرجة كافية.

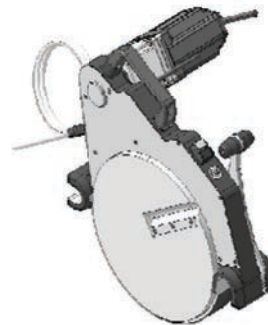

المسواة

2. WELDING GENERAL CRITERIA معايير اللحام العامة

لوحة التسخين

تحقق من سلامة الطلاء.

استخدم ترمومتر رقميًا للتحقق من أنه تم الوصول إلى درجة الحرارة المعدة.

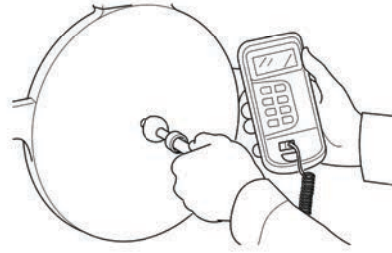

المفصل

قم بعمل لحام اختباري.

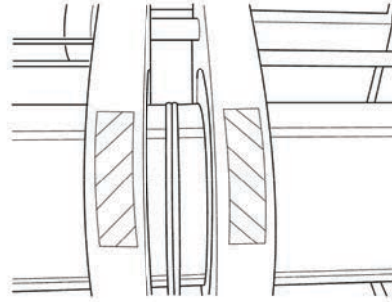

BEFORE WELDING

Measuring Instruments:



Timer



Manometer

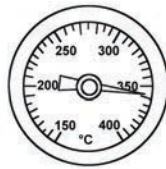

Thermometer

Verify their functionality.

Facer

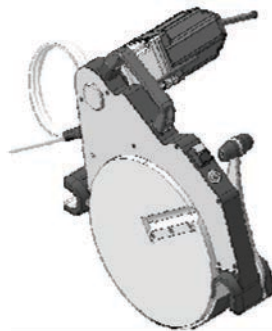

Verify its functionality.

Be sure the blades are sharp enough.

Heating plate

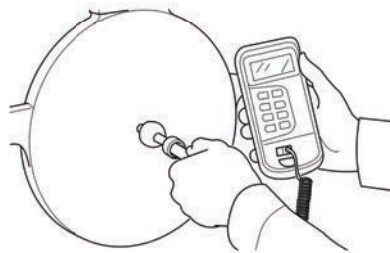

Verify the integrity of the coating.

Use a digital thermometer to check if the temperature set has indeed been reached.

2. WELDING GENERAL CRITERIA معايير اللحام العامة

Joint

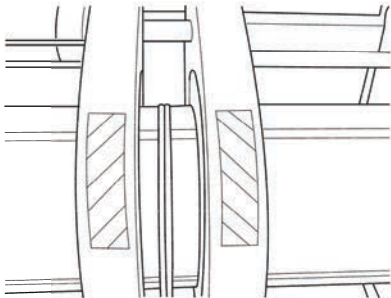

Make a test welding.

2. WELDING GENERAL CRITERIA معايير اللحام العامة

يجب أن يتم اللحام في مكان جاف.
قم بحماية اللحام في حالة الأمطار أو الرطوبة العالية أو الرياح القوية أو درجات الحرارة المرتفعة للغاية أو المنخفضة للغاية.
إذا كان ممنوعاً رفع درجة حرارة اللحام عن استخدام موقدات اللحام أو الموقد، فاجعلها تلامس الأسطح التي سيتم لحامها مباشرة.



ظروف الطقس

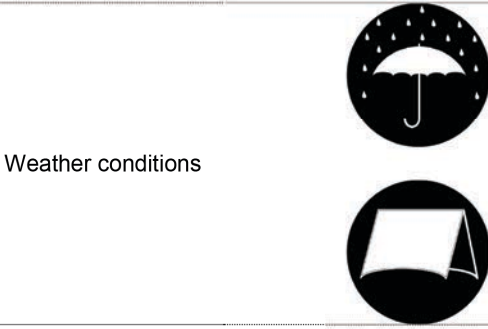

Weather conditions

The welding must take place in a dry place.

Protect the welding in case of rain, high humidity, strong wind, very low or very high temperatures.

It is forbidden to raise the temperature of the welding by means of blowlamps or burners put in direct contact with the surfaces to be welded.

الإعداد

(أ) يجب أن تشمل على

نفس القطر الخارجي الاسمي (D)

نفس السمك الاسمي (s)

→ يجب أن يحترم D و s نطاق التسامح الموضوع من قبل القانون المحلي واللوائح السارية.

(ب) يجب أن تشمل على نفس مستويات السيجما للمنتج (σ).

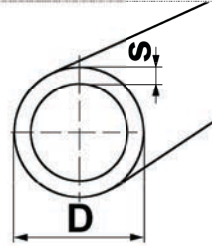

2.2.1 المواسير/التركيبات التي سيتم لحامها

النسبة البيضاوية

$$\frac{D_{max} - D_{min}}{D} \times 100$$

يجب أن تحترم نطاق التسامح الموضوع من قبل القانون المحلي واللوائح السارية.

النسبة

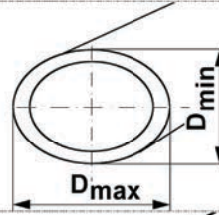

2.2.2 المواسير ذات الشكل البيضاوي

$$\frac{h}{s} \times 100$$

يجب أن تحترم نطاق التسامح الموضوع من قبل القانون المحلي واللوائح السارية.

(h = عمق الخدش/الحز).

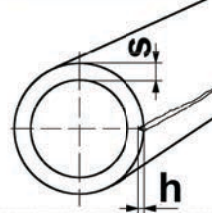

2.2.3 الخدوش والتحزيمات

نظف الأسطح الداخلية والخارجية من الأطراف الملحومة بطريقة صحيحة.

استخدم منتجات التنظيف الموصى بها فقط من قبل الجهة المنتجة للماسورة/التركيبات.

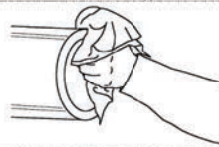

2.2.4 التنظيف

ثبت المواسير بالأسطوانات من أجل تقليل الاحتكاك (وبالتالي التقليل من ضغط السحب P_t).

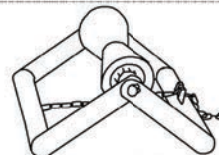

2.2.5 الأسطوانات

ضع سدادات الرياح عند الأطراف غير الملحومة من أجل تجنب تأثير التكدس.

2.2.6 سدادات الرياح

2. WELDING GENERAL CRITERIA معايير اللحام العام

أثناء التثبيت تحقق مما يلي:

يجب ملاقة تلك الحالات الثلاث وفقا للنطاق الموضوع من قبل القانون المحلي واللوائح السارية.



2.2.7

التوازي محاذة المحور الضوء

يجب قياسها مع الماسورة/التركيبية المثبتة في القامطات.

يجب أن تكون دائماً أقل من P_1 و P_5 .

ضغط السحب P_t

2.2.8

SET UP

2.2.1. Pipes/fittings to be welded

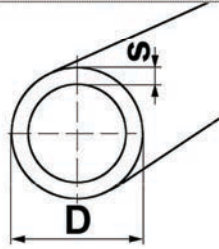

a) They must have

same nominal outside diameter (D)

same nominal thickness (s)

→ D and s must respect the tolerance range established by the National Legislation and regulations in force.

b) They must have the same product sigma (σ).

2.2.2. Oval-shaped pipes

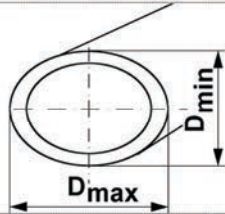

The oval-shaped percentage

$$\frac{D_{max} - D_{min}}{D} \times 100$$

must respect the tolerance range established by the National Legislation and regulations in force.

2.2.3. Scratches and notches

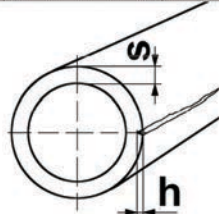

The percentage

$$\frac{h}{s} \times 100$$

must respect the tolerance range established by the National Legislation and regulations in force. (h = scratch/notch depth).

2.2.4. Cleaning



Accurately clean the internal and external surfaces of the ends to be welded.

Use only the cleaning products recommended by the pipe/fitting producer.

2.2.5. Rollers

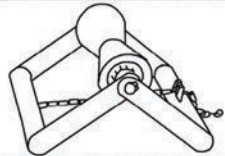

Sustain the pipes with rollers in order to reduce friction (and therefore reduce the dragging pressure P_t).

2.2.6. Wind plugs

Apply the wind plugs to the ends not being welded in order to avoid a stack effect.

While fastening check:

2.2.7.



Parallelism

Axle alignment

Light

These three conditions must be met according to the range established by the National Legislation and regulations in force.

2.2.8 Dragging pressure P_t

Must be measured with pipe/fitting fastened in the clamps.

Must always be inferior to P_1 and P_5 .

2. WELDING GENERAL CRITERIA معايير اللحام العام

دورات اللحام

فيما يلي معلمات اللحام التي يجب أن يقوم المشغل بإعدادها ومراقبتها بعد ذلك:

درجة حرارة لوح التسخين،
الضغط،
أبعاد الخرزة،
طول كل مرحلة.

الصيغ المطلوبة لحساب معلمات اللحام (وفقاً للمركب ومعايير اللحام المستخدمة) موضحة في الفصل ٩، بالإضافة إلى المعلمات الخاصة بالأقطار الأكثر شيوعاً.

دورة اللحام بالضغط البسيط

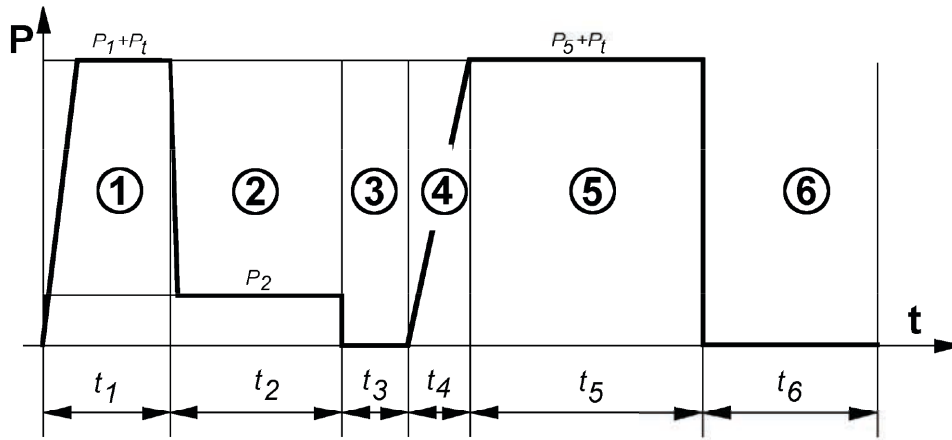

P_1 : الاقتراب والتسخين المسبق

P_2 : الحد الأقصى لضغط التسخين

P_5 : ضغط اللحام

P_t : ضغط السحب (الضغط المطلوب للتغلب على الاحتكاك - يجب أن تتم قراءته من قبل المشغل على مانومتر علبة التروس)

t_1, t_2, \dots, t_6 : طول المراحل 1, 2, ..., 6

المرحلة الأولى الاقتراب والتسخين المسبق تقارب الطرفين اللذين سيتم لحامهما إلى لوح التسخين بضغط مقداره (P_1+P_t) ، وانتظر حتى يصل الخرز إلى العرض المطلوب (UNI ١٠٥٢٠) أو الارتفاع المطلوب (DVS ٢٢٠٧).

المرحلة الثانية التسخين. قلل الضغط إلى أقصى قيمة P_2 ، الكافية لجعل الطرفين ملامسين للوح التسخين للوقت t_2 بالكامل.

هام! يجب ألا يتم مطلقاً فصل الأطراف الملحومة من لوح التسخين أثناء خفض الضغط. إذا حدث ذلك، فإنه يجب بالتأكيد تكرار اللحام.

المرحلة الثالثة فك لوح التسخين. فك لوح التسخين خلال أقصى وقت t_3 ، بدون إتلاف الخرز.

المرحلة الرابعة الوصول إلى ضغط اللحام. اجمع الطرفين مع بعضهما البعض مع زيادة الضغط تدريجياً إلى القيمة الممنوعة التسرب المفرط للمادة الذائبة أثناء القيام بهذه المرحلة.

، أثناء الوقت t_4 ، (P_5+P_t)

المرحلة الخامسة اللحام. حافظ على وجود الطرفين مع بعضهما البعض عند الضغط (P_5+P_t) للوقت t_5 بالكامل.

المرحلة السادسة التبريد. يجب ألا يتم فك المفصل وألا يعاني من أي نوع من أنواع الضغط الميكانيكي لوقت t_6 بالكامل.

لا تستخدم المياه أو الهواء المضغوط لاستعجال التبريد. احم المفصل من المطر أو الرياح أو أشعة الشمس المفرطة.

2. WELDING GENERAL CRITERIA معايير اللحام العامة

WELDING CYCLES

Following are the welding parameters that the operator must set and control afterwards:

- | | |
|----------------------------|-----------------------|
| Heating plate temperature, | Pressures, |
| Bead dimension, | Length of each phase. |

The formulas required to calculate the welding parameters (according to the compound and the welding standards being used) are illustrated in Chapter ٩, as well as the parameters for the most common diameters.

SIMPLE PRESSURE WELDING CYCLE

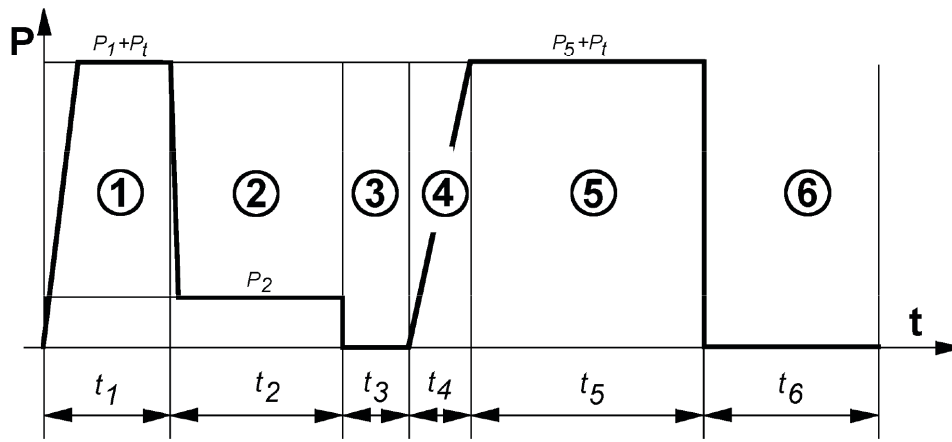

- P_1 : Approach and pre-heating pressure
 P_2 : Maximum heating pressure
 P_5 : Welding pressure
 P_t : Dragging pressure (pressure required to overcome friction - must be read by the operator on the gearcase manometer)

t_1, t_2, \dots, t_6 : Length of Phases 1,2, ..., 6

Phase 1 Approach and Pre-heating. Approach both ends to be welded to the heating plate at the $(P_1 + P_t)$ pressure, and wait until the beads reach the required width (UNI ١٠٥٢٠) or height (DVS ٢٢٠٧).

Phase 2 Heating. Reduce pressure to P_2 maximum value, sufficient to keep the ends in touch with the heating plate for the entire t_2 time.

IMPORTANT! The ends to be welded **MUST NOT** detach from the heating plate while the pressure is being reduced. If that happens, the welding **must absolutely** be repeated.

Phase 3 Removal of heating plate. Remove the heating plate within the maximum t_3 time, without damaging the beads.

Phase 4 Reach of welding pressure. Get both ends together while gradually increasing the pressure up to $(P_5 + P_t)$ value, during t_4 time. Prevent an excessive leakage of melted material while performing this phase.

Phase 5 Welding. Keep both ends together at the $(P_5 + P_t)$ pressure for the entire t_5 time.

Phase 6 Cooling. The joint must not be removed or suffer any sort of mechanical strain for the entire t_6 time.

Do not use water or compressed air to rush cooling. Protect the joint from rain, wind or excessive sunlight.

2. WELDING GENERAL CRITERIA معايير اللحام العام

دورة اللحام بالضغط المزدوج

تستخدم دورة الضغط المزدوج عند لحام PE ١٠٠ بسمك يعادل ٢٠ ملم أو يفوق ذلك.

عند لحام PE ١٠٠ بسمك يقل عن ٢٠ ملم، استخدم دورة الضغط البسيط (الصفحة السابقة).

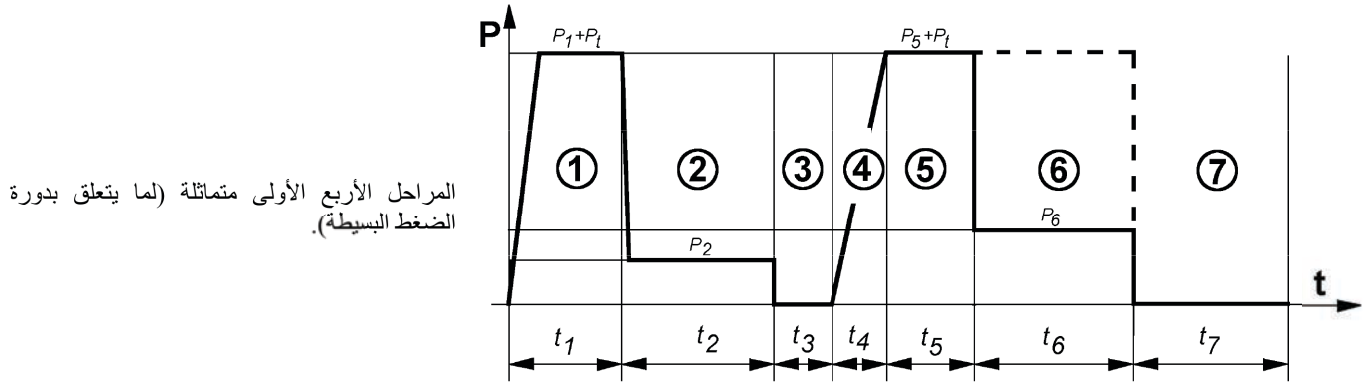

المرحلة 6/5 اللحام. تتم مرحلة اللحام في لحظتين:

١. حافظ على وجود الطرفين مع بعضهما البعض عند الضغط (P_5+P_t) للوقت t_5 بالكامل.

٢. قلل الضغط إلى القيمة P_6 وحافظ الملامسة للوقت t_6 بالكامل.

المرحلة السابعة التبريد. يجب ألا يتم فك المفصل وألا يعاني من أي نوع من أنواع الضغط الميكانيكي لوقت t_7 بالكامل.

DUAL PRESSURE WELDING CYCLE

The Dual Pressure cycle is used when welding PE ١٠٠ with thickness equal or superior to ٢٠mm.

When welding PE ١٠٠ with thickness inferior to ٢٠mm, use the Simple Pressure cycle (previous page).

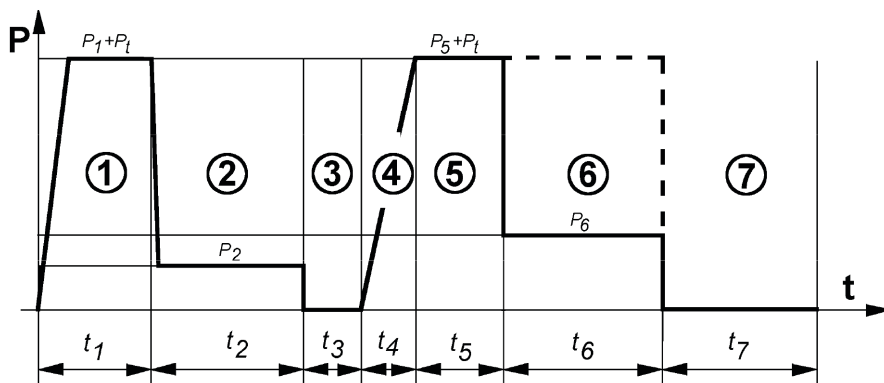

The first four phases are identical (with respect to the simple pressure cycle).

Phases 6/5 Welding. The welding phase happens in two moments:

١. Keep both ends together at the (P_5+P_t) pressure for the entire t_5 time.
٢. Reduce pressure to P_6 value and maintain the contact for the entire t_6 time.

Phase 7 Cooling. The joint must not be removed or suffer any sort of mechanical strain for the entire t_7 time.

2. WELDING GENERAL CRITERIA / معايير اللحام العامة

مراقبة المفصل:

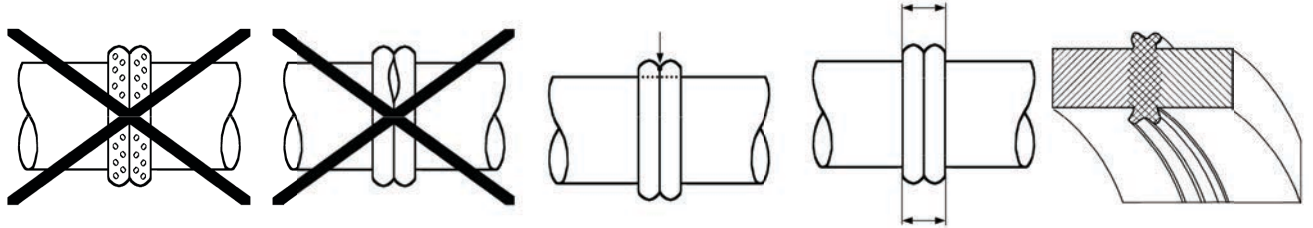

اتبع دائماً إجراءات العمل المحددة من قبل القانون المحلي واللوائح السارية، إلى جانب الإجراءات التي تم تعلمها خلال الدورات التدريبية.

Control the joint:

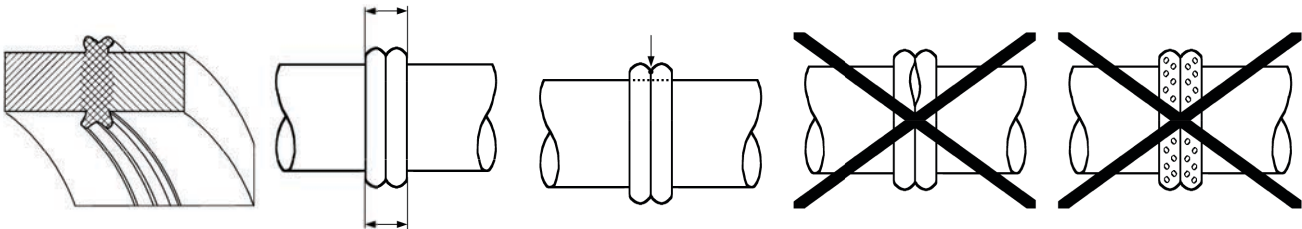

Always follow the working procedures established by the National Legislation and regulations in force, as well as those learnt during the training courses.

3. PARTS DESCRIPTION وصف القطع

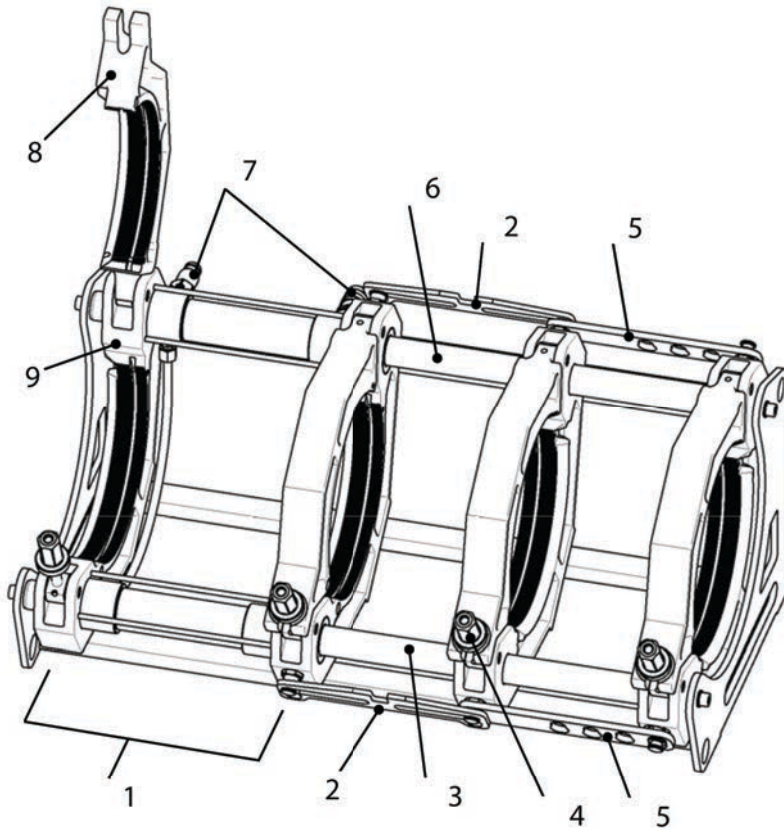

الشاسيه

١. الحاملة المتحركة
٢. اللوحات المعدنية لتحرير لوح التسخين (*)
٣. قضيب الكباس السفلي
٤. مثبت القامطة
٥. قضبان السحب
٦. قضيب الكباس العلوي
٧. وصلات الإقران السريع
٨. الفك العلوي
٩. الفك السفلي

(*) غير موجودة في الموديل BASIC و BASIC 160 و BASIC 200.

CHASSIS

10. Movable carriage
11. Heating plate release plaques (*)
12. Lower piston rod
13. Clamp fastener
14. Dragging bars
15. Upper piston rod
16. Quick-coupling connections
17. Upper jaw
18. Lower jaw

(*) Not featured in the BASIC 160 and BASIC 200 models.

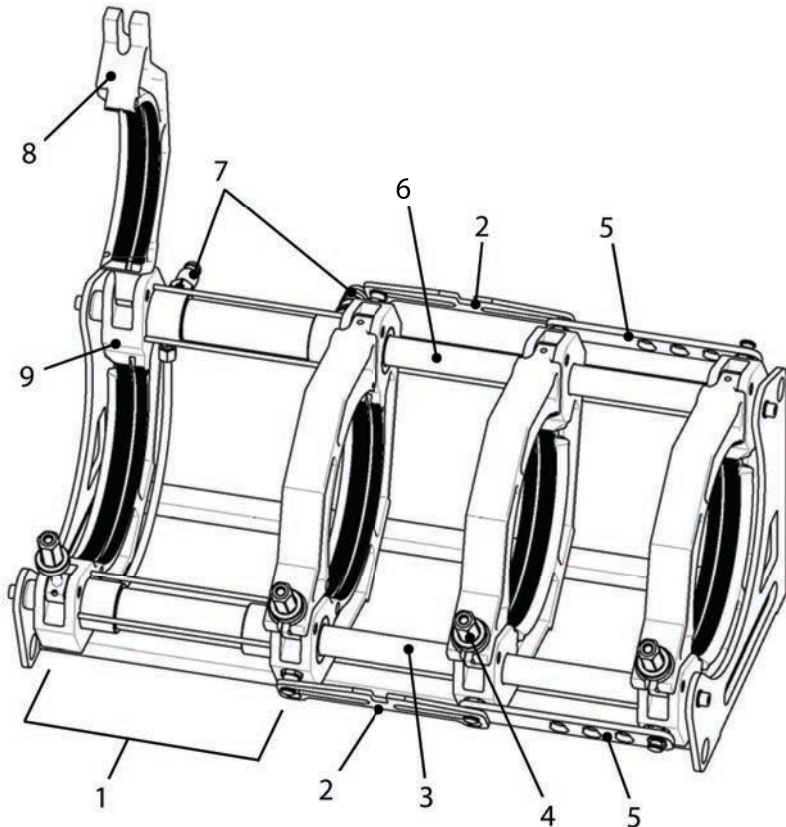

3. PARTS DESCRIPTION وصف القطع

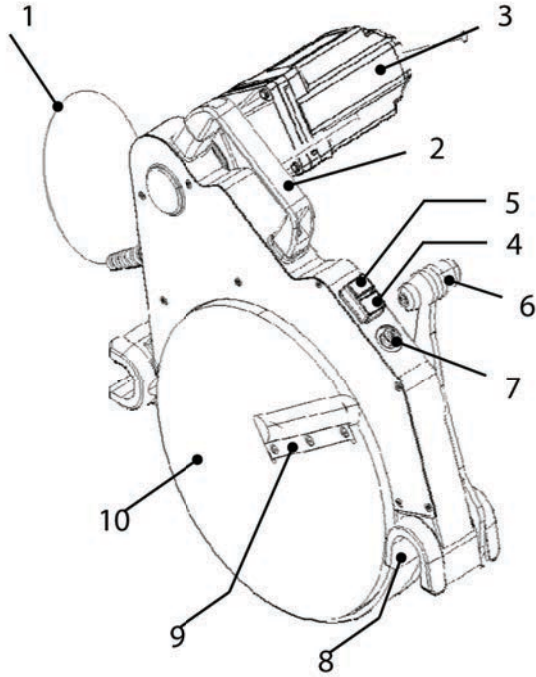

المسواة

١. كبل إمداد الطاقة
٢. مقبض اليد
٣. المحرك
٤. زر البدء الانضغاطي - أخضر (محرك)
٥. زر الإيقاف الانضغاطي - أحمر (محرك)
٦. التراجع المانع
٧. زر قاطع الدائرة الانضغاطي
٨. شوكة دعامة قضيب الكباس
٩. الشفرة
١٠. قرص المسواة

FACER

11. Power supply cable
12. Handgrip
13. Motor
14. Start push button - green (motor)
15. Stop push button - red (motor)
16. Blocking lever
17. Circuit breaker push button
18. Fork for piston rod support
19. Blade
20. Facer disk

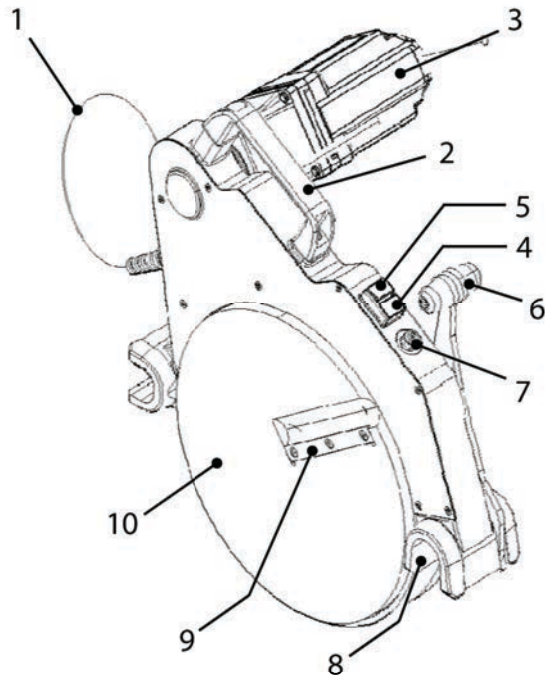

3. PARTS DESCRIPTION وصف القطع

لوح التسخين

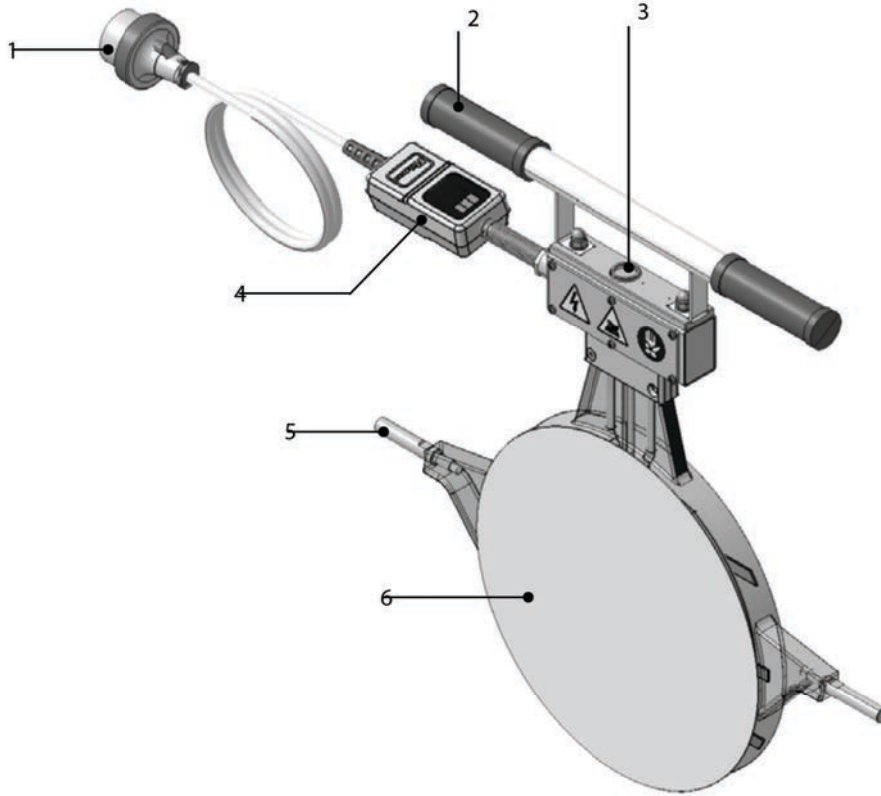

١. مقيس الطاقة
٢. مقبض اليد
٣. ترمومتر التحكم في درجة حرارة اللحم (مستقل عن المنظم الحراري)
٤. المنظم الحراري DIGITAL DRAGON (طالع § ٣/٤)
٥. مسمار دعامة قضيب الكباس
٦. اللوح

3. PARTS DESCRIPTION وصف القطع

HEATING PLATE

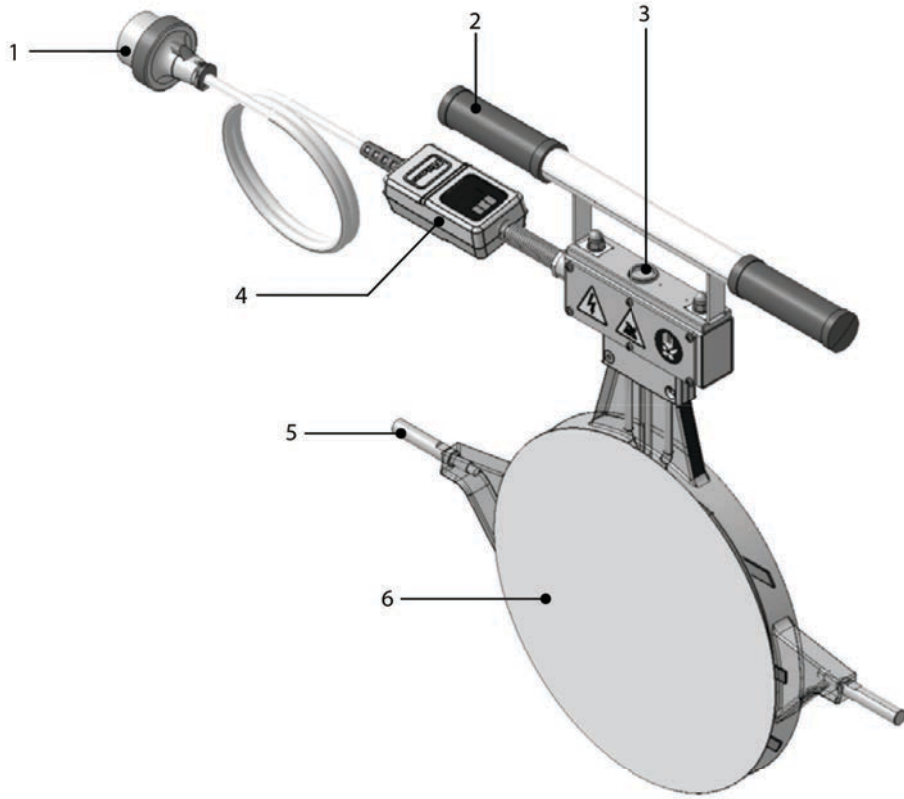

- 7. Power plug
- 8. Handgrip
- 9. Welding temperature control thermometer (independent from thermoregulator)
- 10. Thermoregulator DIGITAL DRAGON (see § 4./٣)
- 11. Pin for piston rod support
- 12. Plate

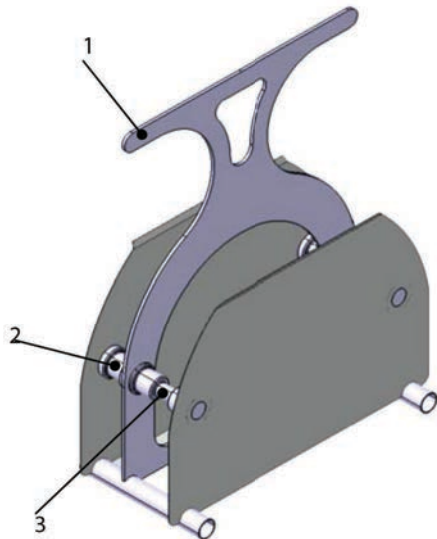

دعامة لوح التسخين/المسواة

- ١. مقبض اليد
- ٢. مبيت لوح التسخين
- ٣. مبيت المسواة

3. PARTS DESCRIPTION وصف القطع

FACER/HEATING PLATE SUPPORT

- 4. Handgrip
- 5. Heating plate housing
- 6. Facer housing

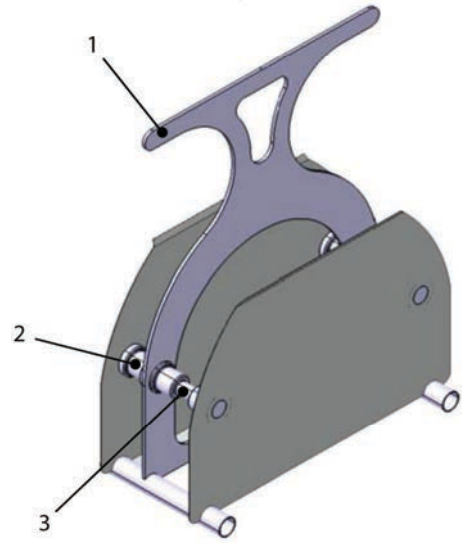

3. PARTS DESCRIPTION وصف القطع

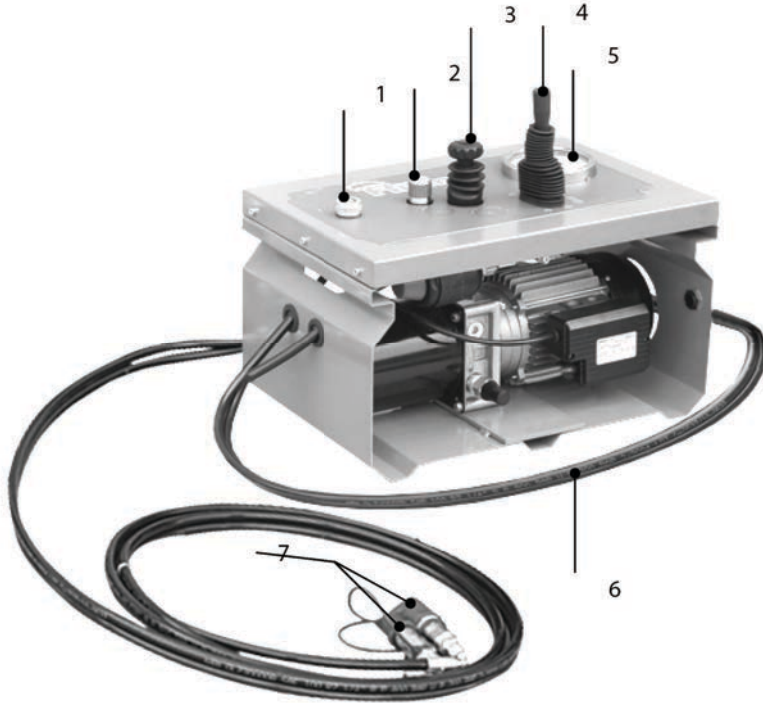

علبة التروس الهيدروليكية

١. سداة خزان الزيت
٢. صمام تصريف الضغط
٣. صمام أقصى مستوى للضغط
٤. ذراع الموزع
٥. مانومتر ضغط الزيت
٦. الخراطيم الهيدروليكية
٧. موصلات الإقران السريع

HYDRAULIC GEARCASE

8. Oil tank plug
9. Pressure discharge valve
10. Maximum pressure valve
11. Distributor lever
12. Oil pressure manometer
13. Hydraulic hoses
14. Quick-coupling connectors

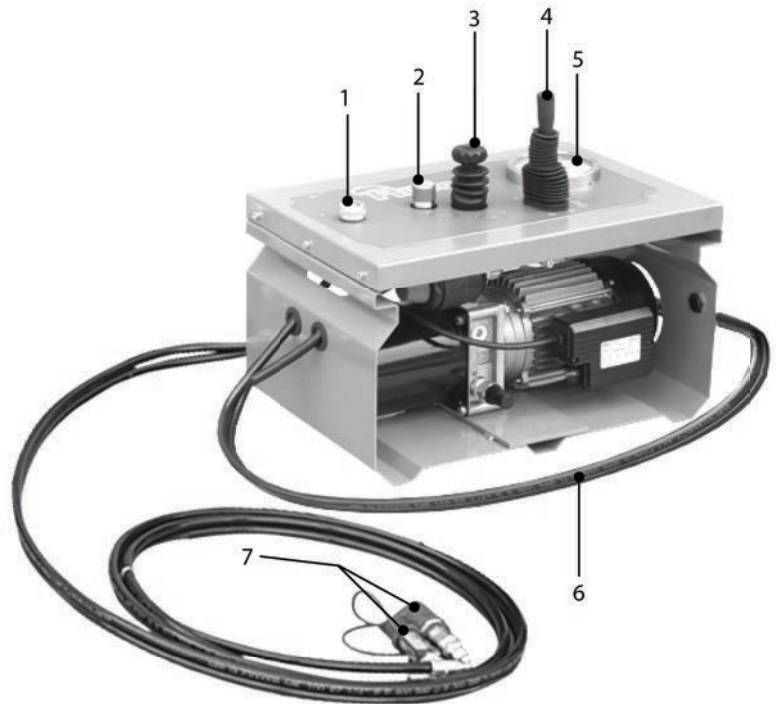

3. PARTS DESCRIPTION وصف القطع

المؤقت

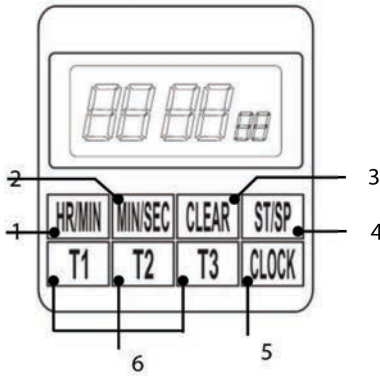

- 1: مفناح ضبط الساعات/الدقائق (في وضع المؤقت 3)
 - 2: مفناح ضبط الدقائق/الثواني (في وضع المؤقت 1 ووضع المؤقت 2)
 - 3: مفناح إعادة الضبط
 - 4: مفناح بدء العد التنازلي/المقاطعة
 - 5: مفناح العطل - عرض/ضبط ساعة التنبيه
 - 6: مفاتيح المؤقت
- وضع T1: إعداد الدقائق/الثواني
وضع T2: إعداد الدقائق/الثواني
وضع T3: إعداد الساعات/الدقائق

TIMER

- 1: Hours/minutes adjustment key (in TIMER 3 mode)
 - 2: Minutes/seconds adjustment key (in TIMER 1 and TIMER 2 modes)
 - 3: Reset key
 - 4: Countdown start/interrupt key
 - 5: Multifunction key – display/adjustment hour-alarm
 - 6: TIMER keys
- T1 mode: Minutes/seconds setup
T2 mode: Minutes/seconds setup
T3 mode: Hours/minutes setup

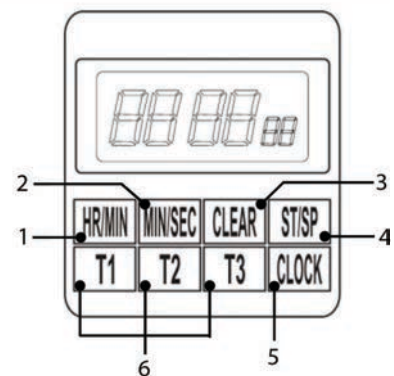

5. MAINTENANCE الصيانة

يجب تنظيف كل مكون بدقة، في نهاية العمليات. قم بحمايتهم من التصادم والسوائل والأوساخ.

Each and every component must be cleaned meticulously, at the end of operations. Protect them against collision, liquids and dirt.

موصلات ووصلات الإقران السريع

حافظ على نظافة الوصلات والموصلات دائماً.

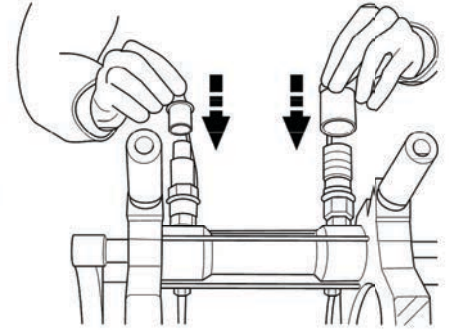

امنع وجود التربة والرمال في الدائرة الهيدروليكية عن طريق الحفاظ على وجود القوابس على الوصلات والموصلات.

QUICK-COUPLING CONNECTIONS AND CONNECTORS

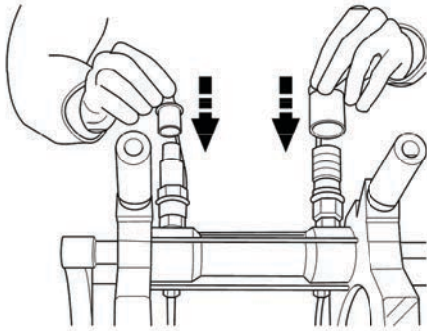

Keep connections and connectors clean at all times.

Prevent earth or sand in the hydraulic circuit by keeping the plugs on the connectors and connections.

الشاسيه

حافظ على نظافة قضبان الأسطوانة دائماً. قم بحمايتها من التصادم.

CHASSIS

Keep cylinder rods clean at all times. Protect them against collision.

علبة التروس الهيدروليكية

HYDRAULIC GEARCASE

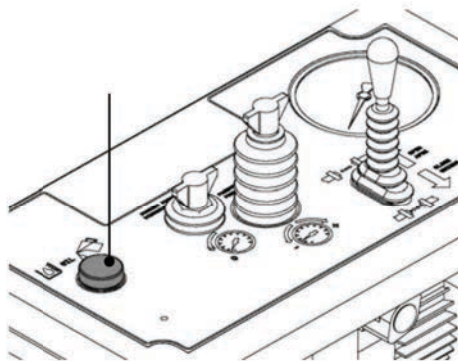

A: غطاء الخزان مع عصا قياس الزيت.

استبدل الزيت بالكامل كل 1000 عملية لحام مرة واحدة كل عام. (الزيت المستخدم يكون ملوثاً للغاية: خذهُ إلى أقرب مكان لتجميع المخلفات الخطيرة.)

استخدم الزيوت الموصى بها فقط (طالع الصفحة ٥ لمعرفة المواصفات).

تحقق من مستوى الزيت مرة واحدة كل شهر. يجب أن يصل إلى علامة المستوى الموجودة على عصا القياس.

5. MAINTENANCE الصيانة

Completely replace oil each ١٠٠٠ weldings and at least once a year. (Used oil is very pollutant: **take it to the nearest hazardous waste collection site.**)

Use recommended oils only (see page ٥ for specifications).

Check the oil level once a month. It must reach the level mark at the dipstick.

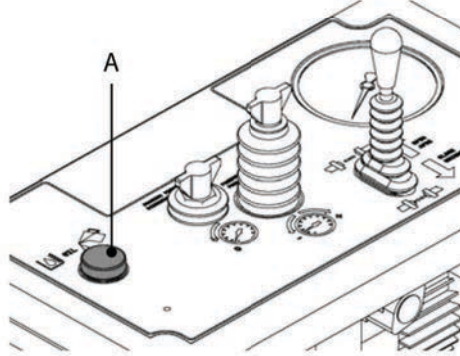

A: Tank cap with oil dipstick.

لوح التسخين
نظف لوح التسخين وضعه في المبيت الخاص ب (لحماية الطلاء) بعد العمليات.

HEATING PLATE

Clean and place the heating plate in its housing (for coating protection) after operations.

FACER المسواة

استبدل الشفرتين بصورة دورية.

نظف المسواة وضعها في المبيت الخاص بها بعد إجراء العمليات.

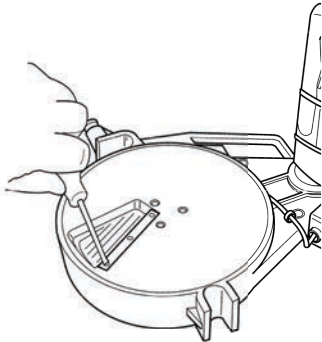
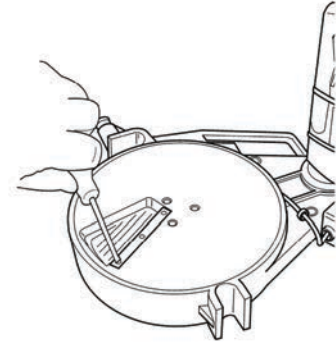

Replace both blades periodically.

Clean and place the facer in its housing after operations.

5. MAINTENANCE الصيانة

Completely replace oil each ١٠٠٠ weldings and at least once a year. (Used oil is very pollutant: **take it to the nearest hazardous waste collection site.**)

Use recommended oils only (see page ° for specifications).

Check the oil level once a month. It must reach the level mark at the dipstick.

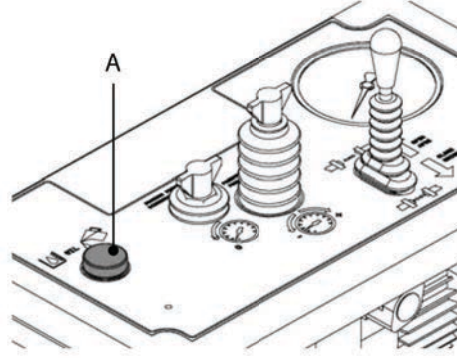

A: Tank cap with oil dipstick.

لوح التسخين
نظف لوح التسخين وضعه في المبيت الخاص ب (لحماية الطلاء) بعد العمليات.

HEATING PLATE

Clean and place the heating plate in its housing (for coating protection) after operations.

FACER المسواة

استبدل الشفرتين بصورة دورية.

نظف المسواة وضعها في المبيت الخاص بها بعد إجراء العمليات.

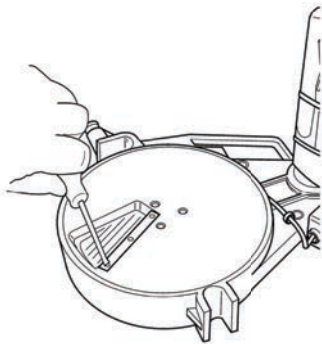
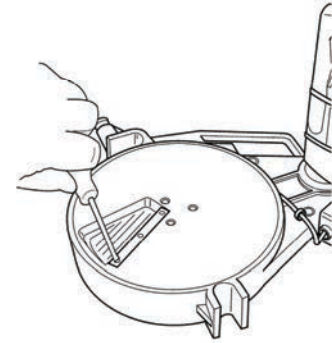

Replace both blades periodically.

Clean and place the facer in its housing after operations.

7. SAFETY PRECAUTION احتياطات السلامة

INTRODUCTION مقدمة

تستخدم ماكينات اللحام **BASIC** من قبل الأفراد المهرة والمعتمدين (*) فقط.

(*) معتمدون وفقاً للقانون واللوائح السارية (مثل، UNI 9737).

تستخدم الماكينة فقط للوظائف الوارد وصفها في الفصل ١ "مقدمة للمنتج والموصفات" وفقاً لتعليمات الاستخدام والصيانة الواردة هنا دائماً. يجب اعتبار أي استخدام آخر غير ملائم وبالتالي يكون ممنوعاً، حيث إنه قد يتسبب في حدوث ضرر في التشغيل/الأطراف الثالثة/الأجسام الأخرى، و/أو بالماكينة نفسها.

يجب أخذ احتياطات السلامة الواردة هنا في عين الاعتبار دائماً.

وبالتالي من الممنوع منعاً باتاً إزالة أي جهاز للسلامة (مثل المفاتيح والمفاتيح الدقيقة وموانع التسرب، إلخ).

استبدل على الفور أي مكون بال أو تالف بقطع غيار **Ritmo** الأصلية فقط.

يجب أن يتم أي شكل من أشكال التدخل على الماكينة من قبل أفراد مهرة ومؤهلين.

*The use of the welding machines **BASIC** is intended for skilled and certified (*) personnel only.*

() Certified according to the Legislation and regulations in force (e.g., UNI 9737).*

The machine is to be used only for the functions described in Chapter \ "Product Introduction and Specifications" and always according to the instructions for use and maintenance herein. Any other use shall be considered improper and is therefore forbidden, as it may cause damage to the operator/third parties/other objects, and/or to the machine itself.

The Safety Precautions herein indicated must be taken into consideration at all times.

It is strictly forbidden to remove each and every safety device (e.g., switches, microswitches, seals, etc.).

Promptly replace any worn-out or damaged component with original **Ritmo** spare parts, only.

Any sort of intervention on the machine must be done by authorized skilled and qualified personnel only.

ELECTRICAL HAZARDS المخاطر الكهربائية

خطر الإعدام بالكهرباء

القطع المتضمنة:
علبة التروس الهيدروليكية
المسواة
لوح التسخين

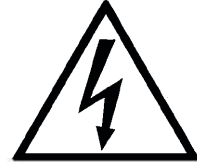

تأكد دائماً من أن المواصفات الكهربائية لإمداد الطاقة تتوافق مع المواصفات الخاصة بالماكينة.

قم بتأريض الماكينة.

راقب ما إذا كان النظام المؤرض يعمل بطريقة صحيحة أم لا.



7. SAFETY PRECAUTION احتياطات السلامة

تأكد من أن لوحة المفاتيح الكهربائية أو من أن المولد الذي تتصل به الماكينة أثناء التشغيل يشتمل على مفتاح تفاضلي حساس (30=ID مللي أمبير).

يجب أن تنتمي مقابس لوحة المفاتيح الكهربائية إلى النوع IEC 309 مع أدنى درجة من الحماية IP44.

لا تدع الماكينة تتعرض إلى الأمطار أو إلى أي سوائل أخرى.

تأكد من أن أجهزة حماية العزل (مثل قفازات السلامة) جافة تمامًا عند استخدام الماكينة.

لا تدع الكبلات مكشوفة للمواد الكيميائية أو للجهد الميكانيكي أو للمخاطر العامة مثل حبال الشد أو الأجسام الحادة أو لممر المركبات أو للمارة، إلخ

افصل الماكينة من مصدر الطاقة بمجرد انتهاء العمليات، أو حتى عند تعليق العمليات لفترة قصيرة.

تحقق من سلامة جميع المكونات قبل استخدام الماكينة. انتبه بصورة خاصة للقطع العازلة وأدلة تمرير الكبلات وجلب الكبلات.

اختبر التدخل الصحيح للمفتاح التفاضلي مرة واحدة كل شهر.

نظف الماكينة ومكوناتها بالكامل بعد الاستخدام. لا تستخدم مواد قد تؤدي إلى تلف قطع العزل، مثل مذيبات التنظيف الجاف أو البنزين (المواد القابلة للاشتعال بصورة عامة) أو السوائل الكاشطة.

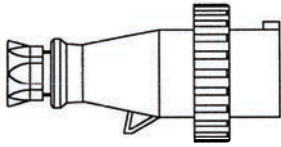

يجب أن تتوافق التمديدات مع اللوائح السارية وأن تكون مناسبة للطاقة المطلوبة. استخدم النوع IEC 309، المقابس IP67 فقط.

معدة فولطية الأمان المنخفضة للغاية (SELV) تكون مطلوبة عند العمل في:

- الأماكن الضيقة
- الأماكن شديدة الرطوبة
- الأماكن المحاطة بالهيكل المعدنية أو بالمياه (مثل مواضع بناء السفن)

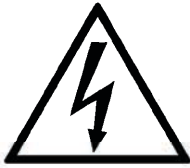

ELECTROCUTION HAZARD

Parts involved: HYDRAULIC GEARCASE
FACER
HEATING PLATE

Be sure that the electrical specifications of the power supply correspond to the ones of the machine.



Earth the machine.

Control if the earthed system is working properly.

7. SAFETY PRECAUTION احتياطات السلامة

Be sure that the panel board or the generator to which the machine is connected during operations has a highly sensitive differential switch ($I_{\Delta}=30\text{ mA}$).

The panel board plugs must belong to the IEC 609 type with IP44 minimum protection degree.

Do not let the machine be exposed to rain or any other liquids.

Be sure that the isolating protection devices (such as the safety gloves) are perfectly dry when you use the machine.

Do not let the cables be exposed to chemical substances, mechanical strain, or general hazards such as tugs, sharp objects, or the passage of vehicles or passers-by, etc.

Unplug the machine from the power source as soon as operations are over, or even momentarily suspended.

Check the integrity of all components before using the machine. Pay particular attention to the isolating parts, cables, cable fairleads and cable glands.

Test the proper intervention of the differential switch once a month.

Thoroughly clean the machine and its components after use. Do not use substances that could damage the isolating parts, such as solvents, gasoline (combustibles in general), or abrasive liquids.

Extensions must comply with the regulations in force and be suitable for the power requested. Use only type IEC 609, IP17 plugs.

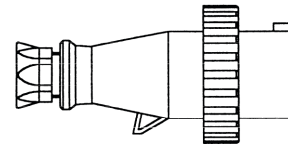

SELV (Safety Extra Low Voltage) equipment is required when working in:

- narrow spaces
- extremely damp places
- sites surrounded by metal structures or water (e.g., shipyards)

BUTT FUSION WELDING MACHINE



BASIC 355 is able to weld fittings such elbows, tees, Y – branches and flange necks without any additional equipment by simply fixing the clamps drag bar.

BASIC 355 includes :

- **A machine body** - with 4 clamps and 2 hydraulic cylinders with fast non-drip couplings.
- **An extractable heating plate** with with **DIGITAL DRAGON**, high – precision thermo – regulator.
- **An electro – hydraulic gearcase**, with a clamp opening and closing lever.
- **A hydraulic hoses** with non-drip quick couplings.

BASIC 355

MATERIALS	HDPE - PB – PP - PVDF
WORKING RANGE	355 + 125 MM
POWER SUPPLY	230 VAC
Single phase	60/50 Hz
Total absorbed power	4500 W
Working Temperature	280 + 180°c
Pressure working range	150 + 0 bar
Weight only body machines	150 kg

STANDARD COMPOSITION

Adapters, from Ø 125 to 315 mm
 Master adapter Ø 250 mm

ON REQUEST (ACCESSORIES)

Tool for flange necks.
 EASY LIFE greabox

Electro Fusion Fittings

Electrofusion fittings Pressure Rating	62
Electrofusion fittings (Approval Testing)	63
Coupler & End Cap	64
Reducer & 90° Elblow	65
45° Elblow & Equal Tee	66
Multiseal Tapping Tee U/P	67
Male & Female Tarnsition Couper	68

Electrofusion Fittings



PRESSURE RAITINGS

The maximum pressure raiting for each type of Electrofusion fitting is in accordance with the table below:

Fitting type	Water (cold)	Gas
Coupler	PN16	6 Bar /10 Bar
Elbow	PN16	6 Bar /10 Bar
Equal Tee	PN16	6 Bar /10 Bar
Reducer	PN16	6 Bar /10 Bar
Tapping tee**	PN16 / PN12.5	6 Bar /10 Bar
Branch Saddle **	PN16 / PN 12.5	6 Bar
Hydrant Products	PN12.5	n/a
Transition Fittings	PN12.5	6 Bar

** PN16 when PE100 resin / PN12.5 when PE80 resin

PRESSURE RAITINGS

The maximum pressure raiting for each type of Electrofusion fitting is in accordance with the table below:

Fitting sizes 63 mm and below		Fitting sizes 63 mm above	
Fitting Type	Pipe SDR	Fitting Type	Pipe SDR
Coupler	11	Coupler	11 TO 17.6
Elbow	11	Elbow	11 TO 17.6
Equal Tee	11	Equal Tee	11 TO 17.6
Reducer	11	Reducer	11 TO 17.6
Tapping tee	11	Tapping tee**	11 TO 17.6
Branch Saddle	11	Branch Saddle **	11 TO 17.6
Hydrant Products	11	Hydrant Products	11 TO 17.6
Transition Fittings	11	Transition Fittings	11 TO 17.6

Testing can be carried out on SDR rated pipe out the stated ranges if required, contact nearest Fusion Provida outlet for details.

ELECTROFUSION FITTING

APPROVAL TESTING

TYPICAL TEST	TEST CRITERIA	WATER SPECIFICATION	GAS SPECIFICATION
20°C Hydrostatic test (5000 hrs)	PE80 - 9.5 Mpa PE100 - 11 Mpa	N/A	GIS/PL2-4 GIS/PL2-6
80°C Hydrostatic test (1000 hrs)	PE80 - 4 Mpa PE100 - 5 Mpa	BS EN12201-3	BS EN1555-3 GIS/PL2-4 GIS/PL2-6
20°C Hydrostatic test (100 hrs)	PE80 - 10 Mpa PE100 - 12.4 Mpa	BS EN12201-3	BS EN1555-3 BS ISO 8085
80°C Hydrostatic test (170 hrs)	PE80 - 4.6 Mpa PE100 - 5.5 Mpa	BS EN12201-3	GIS/PL2-4 GIS/PL2-6 BS EN1555-3 BS ISO 8085
Joint strength/adhesion (socket OD>90mm)	All samples to have 75% ductility	WIS 4-32-08 BS EN12201-3	GIS/PL2-4 GIS/PL2-6 BS EN1555-3 BS ISO 8085
Joint strength/crush (socket OD≤90mm and saddles)	No brittle failure at joint interface	BS EN12201-3	GIS/PL2-4 GIS/PL2-6 BS EN1555-3 BS ISO 8085
Dimensional stability (9000 hrs)	Within specified tolerances after conditioning @ 30°C	n/a	GIS/PL2-4 GIS/PL2-6
Material tests (taken from joint interface after fusion cycle)	MFR, OIT and density within specified limits	BS EN12201-3	GIS/PL2-4 GIS/PL2-6 BS EN1555-3 BS ISO 8085
A.R.E.L. (tensile loading for sockets<75mm)	Specified load for 500 hrs @ 80°C	n/a	GIS/PL2-4 GIS/PL2-6
Tapping tee impact (100 J impact energy)	No cracking or leaking after impact	BS EN12201-3	GIS/PL2-4 GIS/PL2-6 BS EN1555-3 ISO 8085
Tapping tee cutter torque	<45Nm for 32mm O/L<110NM for 63mm O/L	n/a	GIS/PL2-4
Pressure loss across tapping tee	State K value	n/a	GIS/PL2-4
Branch saddle pull off	Outlet pipe to fail before fitting	Internal	Internal

Electrofusion Fittings

COUPLER

PE100 Black - Gas 10 Bar / Water PN16

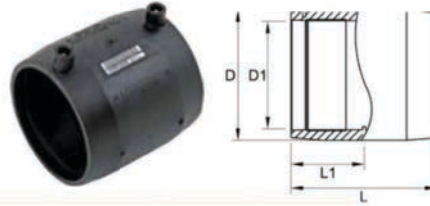

FITTING SIZE	L 1 (MM)	L 1 (MM)	D (MM)	D 1 (MM)	FUSION TIME (SECS)	COOLING TIME (MINS)	WEIGHT (KG)	BOX QUANTITY
20 MM	77	375	29	20	35	3	0.033	80
25 MM	77	375	33.5	25	30	3	0.037	80
32 MM	77	.75	43	32	45	3	0.057	100/75
40 MM	77	44	51.5	40	40	5	0.08	90
50 MM	90	44	61.5	50	90	5	0.096	70
63 MM	93	49	77	63	35	3	0.148	20/25
75 MM	102	61	100	75	50	5	0.403	45
90 MM	125	60	110	90	90	10	0.333	27/30
110 MM	122	70	133	110	160	10	0.52	10/18
125 MM	144	75	151	125	200	10	0.74	12
140 MM	154	89	176	140	200	10	1.45	6
160 MM	181	86	195	160	300	20	1.409	4
180 MM	186	91	220	180	360	20	1.906	4
200 MM	222	92	243	200	440	20	2.301	4
225 MM	220	109	276	225	600	230	4.15	2
250 MM	220	108	301	250	600	30	4.28	2
280 MM (0.4V)	260	127	345	280	600	30	8.22	1
315 MM (40 V)	261	128	386	315	900	30	10.1	1
355 MM (40 V)	260	126	437	355	900	30	12.3	1
400 MM (0.4V)	290	142	475	400	TBC	TBC	14.5	1

END CAP

PE100 Black - Gas 10 Bar / Water PN16

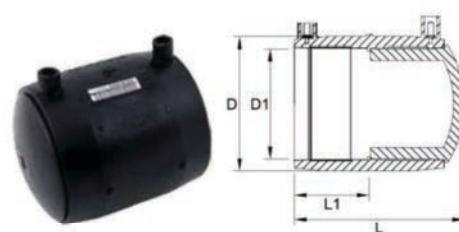

FITTING SIZE	L 1 (MM)	L 1 (MM)	D (MM)	D 1 (MM)	FUSION TIME (SECS)	COOLING TIME (MINS)	WEIGHT (KG)	BOX QUANTITY
20 MM	82	375	29	20	35	3	0.041	80
25 MM	82	375	33.5	25	30	3	0.048	80
32 MM	84	.75	43	32	45	3	0.073	100/75
40 MM	97	44	51.5	40	40	5	0.102	90
50 MM	101	44	61.5	50	90	5	0.15	70
63 MM	115	49	77	63	35	3	0.226	20/25
75 MM	125	61	100	75	50	5	0.553	45
90 MM	138	60	110	90	90	10	0.521	27/30
110 MM	164	70	133	110	160	10	0.97	10/18
125 MM	175	75	151	125	200	10	1.24	12
140 MM	236	89	176	140	200	10	2.25	6
160 MM	202	86	195	160	300	20	2.21	4
180 MM	214	91	220	180	360	20	2.32	4
200 MM	215	92	243	200	440	20	4.2	4
225 MM	222	109	276	225	600	230	7	2
250 MM	220	108	301	250	600	30	8.1	2

Electrofusion Fittings

REDUCER

PE100 Black - Gas 10 Bar / Water PN16

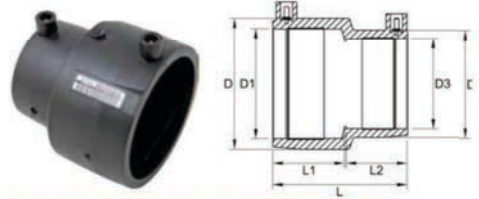

FITTING SIZE	L 1 (MM)	L 1 (MM)	D (MM)	D 1 (MM)	FUSION TIME (SECS)	COOLING TIME (MINS)	WEIGHT (KG)	BOX QUANTITY
25 x 20 mm	77	38.5	34	25	36.5	3	0.035	80
32 x 20 mm	77	38.5	43	32	36.5	3	0.048	75
32 x 25 mm	77	38.5	43	32	36.5	3	0.052	75
40 x 32 mm	84	41	52	40	41	5	0.104	100
50 x 32 mm	91	46.5	62	50	41	5	0.087	80
50 x 40 mm	91	46.5	62	50	43	5	0.92	80
63 x 32 mm	102	52	78	63	44	5	0.13	60
63 x 40 mm	102	52.3	77	63	45	5	0.103	60
63 x 50 mm	102	52	78	63	48	10	0.138	60
75 x 63 mm	125	61	98	75	57	7	0.44	28
90 x 63 mm	122.5	61	109.5	90	55	5	0.3	35
110 x 63 mm	158	80	140	110	58	10	0.62	18
110 x 90 mm	137.5	70	134	110	62	10	0.535	20
125 x 90 mm	145	75	152	125	62.5	10	0.7	12
160 x 90 mm	192	96	200	160	73	22	1.44	4
160 x 110 mm	193	96	200	160	80	22	1.52	6
180 x 125 mm	221	101	216	180	83	10	2.09	4

90° ELBLOW

PE100 Black - Gas 10 Bar / Water PN16

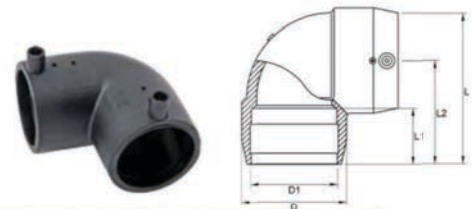

FITTING SIZE	L 1 (MM)	L 1 (MM)	D (MM)	D 1 (MM)	FUSION TIME (SECS)	COOLING TIME (MINS)	WEIGHT (KG)	BOX QUANTITY
20 mm x 90 deg	82	44	64	36	20	3	0.141	40
25 mm x 90 deg	72.4	37.5	55.4	33.85	25	3	0.062	100
32 mm x 90 deg	84	40	62	44	32	3	0.079	80
40 mm x 90 deg	116	50	83	67	40	5	0.34	55
50 mm x 90 deg	116	50	83	67	50	10	0.241	50
63 mm x 90 deg	123.3	50	84.1	80	63	5	0.294	25
75 mm x 90 deg	141	53	92	95	75	5	0.425	25
90 mm x 90 deg	165	59	106	113	90	10	0.685	15
110 mm x 90 deg	205	71	135	137	110	15	1.12	6
125 mm x 90 deg	228	72	152	154	125	15	1.57	6
160 mm x 90 deg	320	104	211	213	160	10	5	2
180 mm x 90 deg	320	104	211	213	180	20	4.12	2

Electrofusion Fittings

45° ELBLOW

PE100 Black - Gas 10 Bar / Water PN16

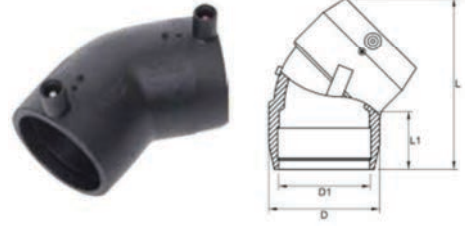

FITTING SIZE	L 1 (MM)	L 1 (MM)	D (MM)	D 1 (MM)	FUSION TIME (SECS)	COOLING TIME (MINS)	WEIGHT (KG)	BOX QUANTITY
32 MM × 45 deg	95	39	44	32	45	3	0.08	100
40 MM × 45 deg	108	41.5	53	40	50	5	0.1	70
50 MM × 45 deg	124	44.5	63.8	50	80	5	0.134	50
63 MM × 45 deg	135.4	50	78.5	63	35	5	0.25	30
75 MM × 45 deg	165	62	97	75	70	10	0.427	35
90 MM × 45 deg	192	82	117	90	110	10	0.765	18
110 MM × 45 deg	213	75	137	110	140	10	0.894	10
125 MM × 45 deg	240	81	154	125	140	10	1.22	6
160 MM × 45 deg	320	105	217	160	240	10	4.5	2
180 MM × 45 deg	320	105	217	180	240	20	3.13	2

EQUAL TEE

PE100 Black - Gas 10 Bar / Water PN16

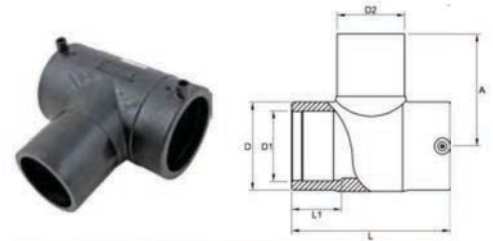

FITTING SIZE	L 1 (MM)	L 1 (MM)	D (MM)	D 1 (MM)	FUSION TIME (SECS)	COOLING TIME (MINS)	WEIGHT (KG)	BOX QUANTITY
20 × 20 × 20 mm	98	35	44	20	78	3	0.13	75
25 × 25 × 25 mm	98	35	44	25	78	3	0.12	75
32 × 32 × 32 mm	98	35	44	32	78	3	0.1	50
40 × 40 × 40 mm	131	44	52	40	91	5	0.163	18
50 × 50 × 50 mm	141	43	64	50	104	5	0.23	25
63 × 36 × 63 mm	156	50	82	63	114	5	0.445	20
75 × 75 × 75 mm	174	60	97	75	126	10	0.597	12
90 × 90 × 90 mm	201	55	115	90	143	8	0.97	7
110 × 110 × 110 mm	239	73	139	110	167	10	1.67	6
125 × 125 × 125 mm	262	79	156	125	196	15	2.3	4
160 × 160 × 160 mm	313	89	200	160	211	20	4.06	2
180 × 180 × 180 mm	330	89	224	180	231	19	5.3	2

Electrofusion Fittings

MULTISEAL TAPPING TEE U/P

PE100 Black - Gas 10 Bar / Water PN16

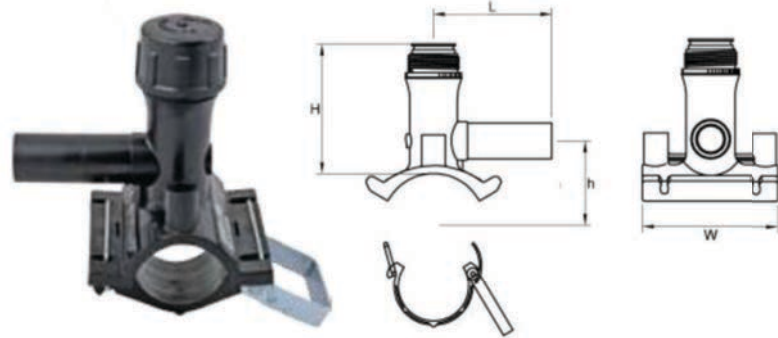

FITTING SIZE	L 1 (MM)	L 1 (MM)	D (MM)	D 1 (MM)	FUSION TIME (SECS)	COOLING TIME (MINS)	WEIGHT (KG)	BOX QUANTITY
40 X 20mm	105	110	27	120	40	3	0.25	10
40 X 25mm	105	110	27	120	40	3	0.25	10
40 X 32mm	105	110	27	120	40	3	0.25	10
50 X 20mm	105	110	27	120	40	3	0.26	10
50 X 25mm	105	110	27	120	40	3	0.26	10
50 X 32mm	105	110	27	120	40	3	0.26	10
63 X 20mm	105	119	62	120	70	10	0.6	10
63 X 25mm	105	119	62	120	70	10	0.6	10
63 X 32mm	105	119	62	120	70	10	0.6	10
75 X 20mm	105	110	77	120	100	10	0.646	10
75 X 25mm	105	110	77	120	100	10	0.646	10
75 X 32mm	105	110	77	120	100	10	0.646	10
90 X 20mm	105	110	77	120	100	10	0.646	10
90 X 25mm	105	110	77	120	100	10	0.646	10
90 X 32mm	105	110	77	120	100	10	0.646	10
110 X 20mm	105	117	86	120	80	10	0.682	10
110 X 25mm	105	117	86	120	80	10	0.682	10
110 X 32mm	105	117	86	120	80	10	0.682	10
125 X 20mm	105	117	95	120	80	10	0.67	10
125 X 25mm	105	117	95	120	80	10	0.67	10
125 X 32mm	105	122	95	120	80	10	0.67	10
160 X 20mm	105	122	112	120	100	10	0.69	10
160 X 25mm	105	122	112	120	100	10	0.69	10
160 X 32mm	105	122	112	120	100	10	0.69	10
180 X 20mm	105	122	122	120	100	10	0.68	10
180 X 25mm	105	122	122	120	100	10	0.68	10
180 X 32mm	105	122	122	120	100	10	0.68	10
200 X 20mm	105	122	132	120	100	10	0.73	10
200 X 25mm	105	122	132	120	100	10	0.73	10
200 X 32mm	105	122	132	120	100	10	0.73	10
225 X 20mm	105	122	122	120	100	10	0.78	10
225 X 25mm	105	122	122	120	100	10	0.78	10
225 X 32mm	105	122	122	120	100	10	0.78	10

Electrofusion Fittings

MALE TARNSION COUPER

PE100 Black - Gas 10 Bar / Water PN16

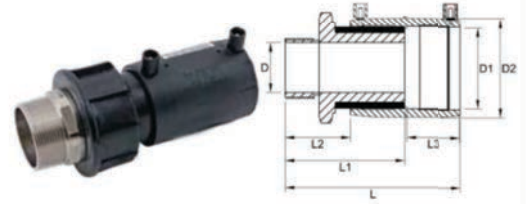

FITTING SIZE	L 1 (MM)	L 1 (MM)	D (MM)	D 1 (MM)	FUSION TIME (SECS)	COOLING TIME (MINS)	WEIGHT (KG)	BOX QUANTITY
25 mm × ¾"	114	79	34	17	30	3	0.4	60
32 mm × ½"	114	79	34	23	45	3	0.425	50
32 mm × ¾"	114	79	34	23	45	3	0.425	50
32 mm × 1"	114	79	34	23	45	3	0.426	50
32 mm × 1¼"	114	79	34	23	45	3	0.431	50
32 mm × 1½"	114	79	34	23	45	3	0.431	50
40 mm × 1"	126	81	34	29	40	5	0.468	50
40 mm × 1¼"	126	83	34	29	40	5	0.468	30
40 mm × 1½"	126	83	34	29	40	5	0.468	30
40 mm × 2"	126	88	34	29	40	5	0.471	30
50 mm × 1"	134	86	34	38	40	5	0.418	20
50 mm × 1¼"	1436	88	36	38	80	5	0.548	20
50 mm × 1½"	136	88	36	38	80	5	0.548	20
50 mm × 2"	141	93	41	38	80	5	0.569	15
63 mm × 1¼"	154	97	36	48	35	3	0.704	15
63 mm × 1½"	154	97	36	48	35	3	0.704	15
63 mm × 2"	159	102	41	48	35	3	0.894	15

FEMALE TARNSION COUPER

PE100 Black - Gas 10 Bar / Water PN16

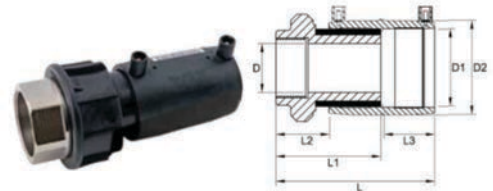

FITTING SIZE	L 1 (MM)	L 1 (MM)	D (MM)	D 1 (MM)	FUSION TIME (SECS)	COOLING TIME (MINS)	WEIGHT (KG)	BOX QUANTITY
25 mm × ¾"	106	68	26	17	30	3	0.4	60
32 mm × 1"	106	68	26	23	45	3	0.426	50
40 mm × 1"	116	73	26	29	40	5	0.418	30
40 mm × 1¼"	116	73	26	29	40	5	0.418	30
40 mm × 1½"	116	73	26	29	40	5	0.408	30
50 mm × 1½"	126	78	26	38	80	5	0.588	20
50 mm × 2"	126	78	26	38	80	5	0.588	15
63 mm × 1½"	148	91	30	48	35	3	0.924	15
63 mm × 2"	148	91	30	48	35	3	0.894	15

Electro Fusion Welding Machine

Q Box Electrofusion Control Box	70
Electra 400 & Electra 800	71
Technical Features	72
Parts Description	73
Control Panel	74-75
Technical Features	76-78
Connection & Generators Features	79

Q BOX ELECTROFUSION CONTROL BOX

Providing all needs in electrofusion pipe jointing for now and the future!

FEATURES :

- Largest brightest in its class
- Improved user interface with helpful on-screen prompts
- Automatic contrast adjustment of the screen
- Remaining joint record memory capacity
- Time until next service
- Input supply voltage
- Time and date
- Well specified control system allowing for future upgrades and improvements
- Joint record data is stored in internal memory and is automatically backed up to removable SD card for complete security.
- Compatible with the data transfer system software; joint record data can easily be downloaded to a readily available USB memory stick for the transfer of data to PC.
- Joint records can be reviewed quickly on screen.
- Fusions unique *touch-key* technology is available on 110 V UK control boxes.
- Count – up timer at the end of jointing allows the cooling time to be monitored
- Robust construction employing high quality die-cast aluminum enclosure and integrated vheat – sink.
- IP 54 rated to EN 60529 preventing ingress of water and dirt
- Improved performance allows use with larger fittings
- Plus all the existing functions of a Fusion Control Box



IMPROVED MAINTENANCE AND SERVICING:

- Quick and easy calibration using the keypad
- Intelligent design allowing fascia screen and keypad to be replaced quickly and independently, reducing potential maintenance costs
- As and when the operating software is improved it can be updated quickly and easily via a USB memory stick
- Improved lead and assemblies and sense pin designed for strength, durability and ease of maintenance
- Input and output cables are more flexible and user friendly
- Standard box can be upgraded with a barcode reader if required.

WORKING RANGE : ELEKTRA 400 Ø 400 - 20 MM; ELEKTRA 800 Ø 800 - 20 MM



ELEKTRA 400 ELEKTRA 800



Elektra is an universal electro fusion machine, suitable for welding HDPE and PP couplings (from 8 to 48 V). It is available in two versions: ELEKTRA 400, ELEKTRA 800. The Elektra machine is made in compliance with Italian and international standards, and is composed of:

- A versatile machine body. Capable of adapting different cooperation needs, inside the French, The control panel can be tilted upward or be positioned horizontally to the ground.
- An optical scanner – barcode reading system (or optical pen, upon request) that automatic setting of the welding parameters. There are nonetheless two manual settings available: by setting the welding tension/time parameters, and by inputting the numerical code indicated under the bar code.
- An in-built memory with 4000 welding cycles, featuring the possibility of transferring data to a PC/Laptop, to an external USB storage device, or to a serial printer RS – 232.
- A large graphic display.

STANDARD COMPOSITION

- Universal adapter (...) 4,7 – 4,0 mm;
- Optical scanner;
- Manual scraper;
- Transport case.

ASK FOR A QUOTATION



TECHNICAL FEATURES

	ELEKTRA 400	ELEKTRA 800
Working range	400 + 20 mm	800 + 20 mm
Working output voltage	48 + 8 v (**)	
Single phase power supply	110 V 60/50 Hz	230 V 60/50 Hz
Max. absorbed power	2500 W	3500 W
Max. output current	100 A	120 A
60 % Duty Cycle output	65 A	90 A
Operating mode	Barcode / Manual (numerical code or tension/time)	
Connections	USB for external memory and RS 232serial printer	
Memory capacity	4000 reports	
Protection degree	IP 54	
External T* reading probe	(+-) 1* C	
Outside T* range	- 50 + *10* C	
Display	128 X 64 graphic back lighted LCD	
Welding hose length	3 mt	
Dimension	358 X 285 X 302 mm	
Weight	19.5 Kg	22.5 Kg



USB Storage device



RITMO Transfer

ON REQUEST (ACCESSORIES)

- RITMO Transfer (data transfer software);
- Optical pen, for reading barcodes.



Agru, Aquatechnik, Aquathem, Banninger, Cetral, Plastic, Coprax, Degaz, Durapipe, Gecosestym (**)
Nupi (Elofit, Niron, Polysistem). Girpi, Eurostandard, Firat, Friatec, Fusion, Georg Fischer, Innoge, .
(Hydroblok, Maribs, Plasson, Plastitalia, Simona, Strengwled, Technima, Tega, Uponor, Wavin (Monoline

PARTS DESCRIPTION وصف القطع

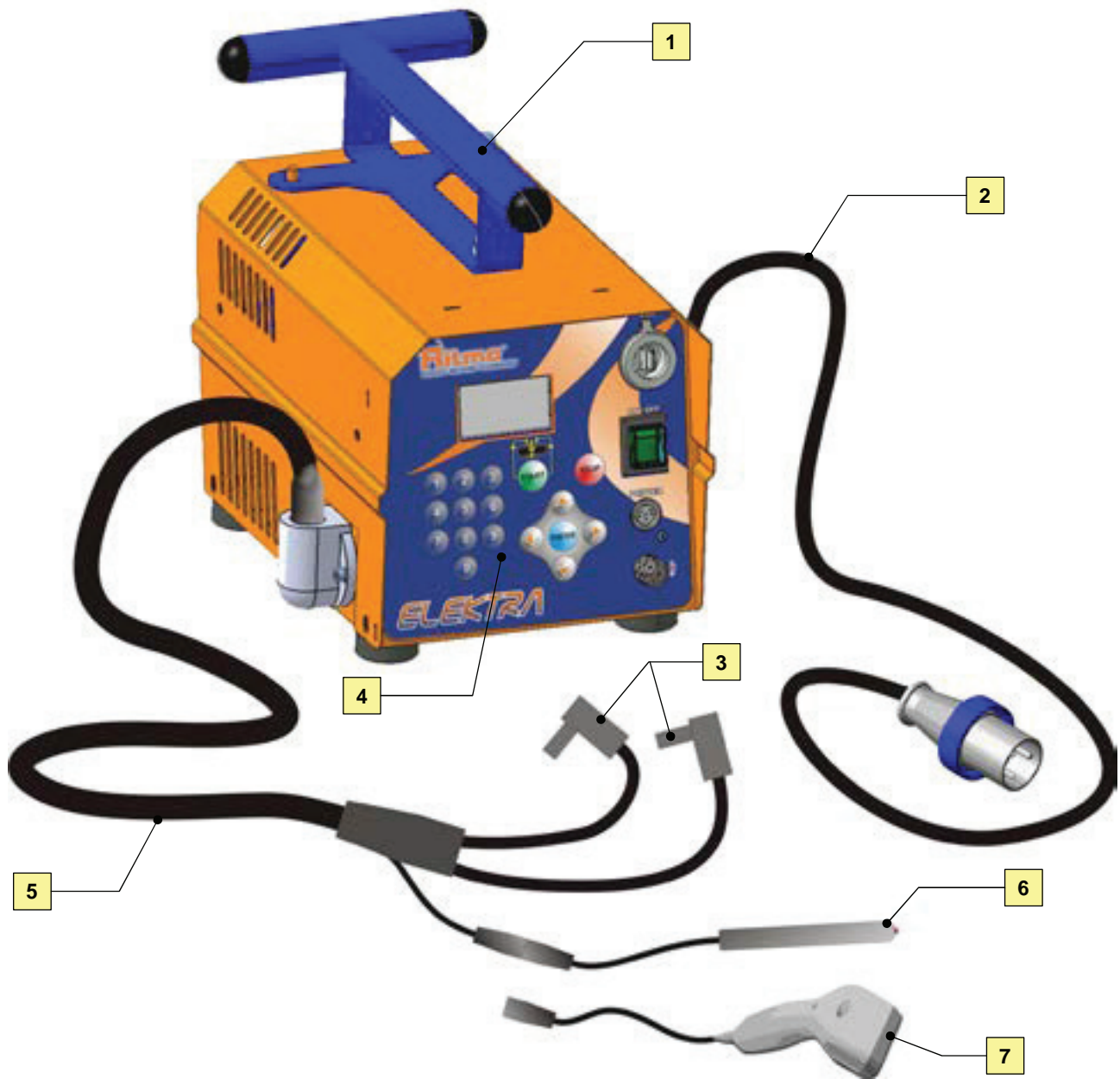

1. مقبض الرفع
2. كبل الطاقة
3. موصلات اللحام
4. لوحة التحكم
5. كبل اللحام
6. القلم البصري لقراءة الباركود
7. ماسح ضوئي لقراءة الباركود (خيارى)

7. Lifting handle
8. Power cable
9. Fusion Connectors
10. Control Panel
11. Fusion Cable
12. Optical Pen for bar code reading
13. Scanner for bar code reading (optional)

CONTROL PANEL



- .A الشاشة
- .B لوحة المفاتيح الرقمية
- .C مفاتيح تمرير القائمة/المؤشر
- .D مفتاح ENTER (إدخال) (لتأكيد ضبط البيانات والمتابعة إلى الخطوة التالية)
- .E مجس درجة الحرارة الخارجية
- .F موصل للطابعة التسلسلية / نقل البيانات إلى الكمبيوتر الشخصي
- .G مفتاح ON/OFF (التشغيل/إيقاف التشغيل)
- .H منفذ USB لنقل البيانات إلى ذاكرة USB
- .I مفتاح STOP (إيقاف) (للخروج من القائمة بدون حفظ البيانات. لإيقاف عملية اللحام)
- .J مفتاح START (البدا) (لبدا اللحام)

- A.** Display
- B.** Numeric keyboard
- C.** Menu/Cursor scroll keys
- D.** ENTER key (Confirms data set and proceeds to next step)
- E.** External temperature probe
- F.** Connector for Serial Printer / Data Transfer to PC
- G.** ON/OFF Switch
- H.** USB Port for Data Transfer to USB memory
- I.** STOP Key (Exits from menu without saving data. Stops fusion process)
- J.** START Key (Begins Fusion)

Technical Features

ELEKTRA 800 220 فولط	ELEKTRA 400 220 فولط	ELEKTRA 400 110 فولط	
800 ملم	400 ملم	400 ملم	الحد الأقصى لنطاق العمل
PE / PP / PP- R	PE / PP / PP- R	PE / PP / PP- R	المواد المنصهرة
285 x 302 x 358 ملم	285 x 302 x 358 ملم	285 x 302 x 358 ملم	الأبعاد
22.5 كلجم	19.5 كلجم	19.5 كلجم	الوزن (بدون حاوية النقل)
220 فولط ± 15%	220 فولط ± 15%	110 فولط ± 15%	الجهد المطلوب
60 هرتز	60 هرتز	60 هرتز	التردد
3500 وات	2700 وات	2500 وات	الحد الأقصى للطاقة الممتصة
16 أمبير	12 أمبير	22 أمبير	التيار الاسمي
100 أمبير	80 أمبير	75 أمبير	التيار الاسمي للحام دورة التشغيل 30% (ISO 12176-2)
90 أمبير	70 أمبير	65 أمبير	التيار الاسمي للحام دورة التشغيل 60% (ISO 12176-2)
80 أمبير	60 أمبير	55 أمبير	التيار الاسمي للحام دورة التشغيل 100% (ISO 12176-2)
10- درجة مئوية ± 40 + درجة مئوية	10- درجة مئوية ± 40 + درجة مئوية	10- درجة مئوية ± 40 + درجة مئوية	درجة حرارة التشغيل
8 - 48 فولط	8 - 48 فولط	8 - 48 فولط	جهد اللحام
120 أمبير	100 أمبير	100 أمبير	أقصى سعة أمبيرية
± 1 درجة مئوية	± 1 درجة مئوية	± 1 درجة مئوية	دقة ترمومتر البيئة المحيطة
IP 54	IP 54	IP 54	درجة الحماية
F 4 ملم	F 4 ملم	F 4 ملم	قطر الموصل
F 4.7 ملم	F 4.7 ملم	F 4.7 ملم	قطر المهابئ
4000 تقرير	4000 تقرير	4000 تقرير	ذاكرات اللحام المتاحة

	ELEKTRA 400 110V	ELEKTRA 400 220V	ELEKTRA 800 220V
Max Working Range	400 mm	400 mm	800 mm
Fusable Materials	PE / PP / PP- R	PE / PP / PP- R	PE / PP / PP- R
Dimensions	358 x 285 x 302 mm	358 x 285 x 302 mm	358 x 285 x 302 mm
Weight (without transport case)	19,5 kg	19,5 kg	22,5 kg
Required Tension	110 V ± 15%	220 V ± 15%	220 V ± 15%
Frequency	60 Hz	60 Hz	60 Hz
Max power absorbed	2500W	2700W	3500W
Nominal current	22A	12A	16A
Fusion nominal current Duty cycle 30% (ISO 12176-2)	75A	80A	100A
Fusion nominal current Duty cycle 60% (ISO 12176-2)	65A	70A	90A

- **WARNING!** When using electric tools, follow safety standards to avoid fire and electric hazards.
- **KEEP WORKPLACE CLEAN.** Untidiness on the workplace may be cause of accidents.
- **CAREFUL TO AMBIENT CONDITIONS.** Do not expose electric tools or fusion machines to the rain. Do not use electric tools or fusion machines in humid places. Make sure lighting is appropriate. Do not use electric tools or fusion machines near liquids or inflammable gases.
- **PROTECT YOURSELF FROM ELECTRIC HAZARD.** Avoid contact with objects connected to earth. Be careful not to touch electric cables.
- **KEEP UNAUTHORIZED PEOPLE AWAY FROM WORKPLACE.** Electric tools and fusion machines can be used only by authorized people. Keep unauthorized people away from workplace.
- **KEEP ELECTRIC TOOLS AND FUSION MACHINES IN A SAFE PLACE.** Electric tools, fusion machines and tools in general have to be stored in dry and safe places not reachable by unauthorized people.
- **DO NOT OVERWORK POWER TOOLS.** Keep within limits given by manufacturer for the best performance, for more time and in safe conditions.
- **ALWAYS USE SPECIFIC TOOLS AND ACCESSORIES ACCORDING TO THE JOB.** Always use accessories compatible with fusion machine (***be careful especially with power generators, extensions for power cables, fusion cable and adapters***). Let power tools to cool down after using for a long time. The use of tools or accessories different from the ones recommended by manufacturer may cause injuries to operator, affect performance of the fusion machine and other tools and void warranty.
- **DO NOT USE CABLES OF FUSION MACHINE OR OTHER TOOLS FOR INCORRECT PURPOSES.** Do not use cables to move machine around or to disconnect from power outlet. Protect cables and fusion machine from warm environments and from contact with sharp objects.
- **ALWAYS USE SPECIAL ALIGNERS.** Always align pipes and fittings using special aligner. This helps to perform a correct fusion and a safe job.

- **WARNING! AVOID ACCIDENTAL STARTING OF POWER TOOLS OR FUSION MACHINE.** Fusion machine has to be disconnected from generator before turning this one on in order to avoid current peaks which can seriously damage electronic components of the machine. Keep machine disconnected from power supply when connecting adapters. Make sure switch is not in the **ON Position** when connecting power tools to power supply or generator (especially if tool is not equipped with safety switch). Do not carry power tools around while they are connected to power supply since they may start accidentally.
- **BEFORE STARTING FUSION PROCESS MAKE SURE FUSION MACHINE IS NOT DAMAGED.** Before using fusion machine **make sure safety devices are perfectly working**. Make sure power cable or fusion cable are not damaged or cut; check that connectors and adapters fit correctly and surfaces in contact are clean. Make sure machine's frame is not severely damaged (water infiltrations may occur).
- **MAINTENANCE AND SERVICE MUST BE PERFORMED BY AUTHORIZED SERVICE CENTRES ONLY.** This machine is manufactured according to safety standards in force therefore maintenance and service can be performed by authorized service centres only otherwise manufacturer declines all responsibilities and warranty is void.
- **DO NOT PERFORM ANY MODIFICATION TO THE MACHINE.**
- **OPERATORS HAVE TO BE CAREFULLY TRAINED ON THE USE OF THE MACHINE.**
- **USE NEW EQUIPMENT OR EQUIPMENT SERVICED BY AUTHORIZED SERVICE CENTRES AT ALL TIMES.**
- **PRESCRIPTIONS DESCRIBED BY D. Lgs. 09/04/08 n° 81 REGARDING SAFETY IN THE WORKPLACE MUST BE FOLLOWED.**
- **DO NOT USE MACHINE IN EXPLOSIVE ENVIRONMENTS** (when in presence of inflammable gases or steams, etc.).



ALwasail



الوسائل

Alwasail Industrial Co. شركة الوسائل الصناعية



CERTIFICATE

Management system as per
EN ISO 9001 : 2008

In accordance with TÜV NORD CERT procedures, it is hereby certified that

Al Wasail Industrial Company
Buraidah Industrial City, P. O. Box 5033
Al Qassim
Kingdom of Saudi Arabia

applies a management system in line with the above standard for the following scope

Wide variety of HDPE, LLDPE & LDPE Pipes, Barb Fittings, Clamp Saddle, Drippers & Bubblers, Pop-up & Sprinkler, Ball Valve Boxes, Filters, Risers, Thread Fittings, Butt Welding Fittings and other Irrigation items

Certificate Registration No. 44 100 100801
Audit Report No. 5700 1528

Valid from 2016-06-12
Valid until 2018-09-14
(until 2019-06-11 in case of Upgrade to ISO 9001:2015)
Initial certification 2010

Certification Body
at TÜV NORD CERT GmbH

Dammam, 2016-06-12

This certification was conducted in accordance with the TÜV NORD CERT auditing and certification procedures and is subject to regular surveillance audits.

TÜV NORD CERT GmbH

Langemarckstraße 20

45141 Essen

www.tuev-nord-cert.com



NSF International

RECOGNIZES

Al Wasail Industrial Company
Facility: Buraydah, Saudi Arabia

AS COMPLYING WITH NSF/ANSI 14, 61 AND ALL APPLICABLE REQUIREMENTS.
PRODUCTS APPEARING IN THE NSF OFFICIAL LISTING ARE
AUTHORIZED TO BEAR THE NSF MARK.



ANSI
Certification Program
Accredited by the
International National
Standards Institute



Certification Program
Accredited by the
Standards Council
of Canada

This certificate is the property of NSF International and must be returned upon request. For the most current and complete information, please access NSF's website (www.nsf.org).

November 6, 2012
Certificate# C0034107 - 03

David Parkiss, General Manager, Water Systems
Water Distribution Systems

Our Ref: GH/M1302015
Test Report: MAT/LAB 315G

23rd July 2013

Al Wasail Industrial Company
P. O. Box 124
Buraydah
Kingdom of Saudi Arabia



WATER REGULATIONS ADVISORY SCHEME (WRAS)
MATERIAL APPROVAL

The material referred to in this letter is suitable for contact with wholesome water for domestic purposes having met the requirements of BS 6920-1:2000 'Suitability of non-metallic products for use in contact with water intended for human consumption with regard to their effect on the quality of the water'.

The reference relates solely to its effect on the quality of the water with which it may come into contact and does not signify the approval of its mechanical or physical properties for any use.

POLYETHYLENE - COMPONENTS

5240

Al Wasail KSA. Black coloured, extruded polyethylene pipe. For use with water up to 60°C.

APPROVAL NUMBER: 1404500
APPROVAL HOLDER: AL WASAIL INDUSTRIAL COMPANY

The Scheme reserves the right to review approval. This approval is valid between April 2014 and April 2019.

An entry, as above, will accordingly be included in the Water Fittings Directory on-line under the section headed, "Materials which have passed full tests of effect on water quality".

The Directory may be found at: www.wras.co.uk/directory

Yours faithfully

Jason Furnival
Approvals & Enquiries Manager
Water Regulations Advisory Scheme

Water Regulations Advisory Scheme Ltd,
30 Fern Close, Pen-Y-Fan Industrial Estate
Oske Dale, Covent, NP11 3EH
Tel: +44 (0) 333 207 8030. Fax: +44 (0) 1495 240 540
Email: info@wras.co.uk. Website: www.wras.co.uk

The Water Regulations Advisory Scheme Ltd
Registered in England No. 05583930
Registered Office: 1 Queen Anne's Gate,
London, SW1H 9BT

BUREAU VERITAS
Certification



Certificate of Conformity

Awarded to:

AL WASAIL INDUSTRIAL COMPANY

Head Office:

Alwasail Building, King Abdullah Road, Hayal Maroj, Exit 10
PO Box No 21599 Riyadh 11485 K.S.A.

Operative Site:

PO Box No 5033 Buraidah Al-Gassim 51422 K.S.A.

Bureau Veritas Italia S.p.A. certifies that the following products:

Polyethylene pipes (PE)

Designation	SDR	MOP	from DN	to DN
PE 100	11	10	20	630
PE 100	17	6.25	40	630
PE 80	11	8	20	250
PE 80	17	5	20	250

Commercial Brand:

AL WASAIL GAS

Code compound:

PE100: B9L, P00, B92H, E9
PE80: FG, EB, B41

Have been evaluated and found in accordance with the requirements of the standard:

EN 1555-2:2010

Plastics piping systems for the supply of gaseous fuels
Polyethylene (PE) – Part 2: Pipes

Certificate issued in conformity to: RG-01-03 ACCREDIA Rev.00 and TQR-REG-02 Bureau Veritas Rev. 05 – Regulation for the certification of product / process / service.

Original Emission date: 21/04/2010
Current Emission date: 19/03/2016
Expiration date: 18/03/2019

The validity of this certificate is subject to a constant periodical surveillance and it can be checked on the following website: www.bureauveritas.it - Further clarifications regarding the scope of this certificate and the applicability of standard's requirements may be obtained by consulting the organisation.

(Eng. Francesco Sutera – Technical Director)

Certificate N°: **524/001**



SGQ N° 006A PLS N° 079C
SCA N° 008D SGE N° 009H
PCO N° 005B SHAS N° 006P
SCR N° 008F SHG N° 009D
PSMS N° 003E TSP N° 006E

Member degli Accordi di Mutuo Riconoscimento EA e IAF
Signatory of EA and IAF Mutual Recognition Agreements

Bureau Veritas Italia S.p.A. – Via Miramare, 15 – 20126 Milan (MI) – ITALY



BUREAU VERITAS
Certification



Certification

Awarded to

AL WASAIL INDUSTRIAL COMPANY

Head Office:

Alwasail Building, King Abdullah Road, Hayal Maroj, Exit 10
PO Box No 21599 Riyadh 11485 K.S.A.

Operative Site:

PO Box No 5033 Buraidah Al-Gassim 51422 K.S.A.

Bureau Veritas Italia S.p.A.- Industry Division certifies that the following products:

Polyethylene (PE) structured wall piping systems

Joint method	Type	Area	SN	from DN/ID	to DN/ID
Coupler	B	U	4	100	200
Coupler	B	U	8	100	200

Brand:

AL WASAIL

Have been audited and found to be in accordance with the requirements of the:

EN 13476-3:2007+A1:2009

Plastics piping systems for non-pressure underground drainage and sewerage.
Part 3: Specifications for pipes and fittings with smooth internal and profiled external surface and the system, Type B

Certification issued in conformity to TQR-REG-02 Bureau Veritas Rev. 05 - Regolamento generale per la certificazione di conformità di prodotto.

Original Emission Date: 25/11/2014

Expiration date: 24/11/2017

The validity of this certificate is subject to a constant periodical surveillance and it can be checked on the following website:
www.certification.bureauveritas.it Further clarifications regarding the scope of this certificate and the applicability of standard's requirements may be obtained by consulting the organisation.



Yurki
Certificato n° 524/004

Bureau Veritas Italia S.p.A. - Industry Division Via Miramare, 15 - 20126 Milano - ITALIA

BUREAU VERITAS
Certification



Certificate of Conformity

Awarded to:

AL WASAIL INDUSTRIAL COMPANY

Head Office:

Alwasail Building, King Abdullah Road, Hayal Maroj, Exit 10
PO Box No 21599 Riyadh 11485 K.S.A.

Operative Site:

PO Box No 5033 Buraidah Al-Gassim 51422 K.S.A.

Bureau Veritas Italia S.p.A. certifies that the following products:

Electrofusion socket fitting (PE)

Designation	Figure	MOP	SDR	S	from DN	to DN
PE 100	Electrofusion Coupler	10	11	5	75	250

Commercial Brand:

AL WASAIL ELECTROFUSION

Compound codes:

PE100: B9I, P00

Have been evaluated and found in accordance with the requirements of the standard:

EN 1555-3:2010+A1:2012

Plastics piping systems for the supply of gaseous fuels
Polyethylene (PE) - Part 3: Fittings

Certificate issued in conformity to: RG-01-03 ACCREDIA Rev.00 and TQR-REG-02 Bureau Veritas Rev. 05 – Regulation for the certification of product / process / service.

Original Emission date: 16/06/2016
Current Emission date: 16/06/2016
Expiration date: 15/06/2019

The validity of this certificate is subject to a constant periodical surveillance and it can be checked on the following website: www.bureauveritas.it - Further clarifications regarding the scope of this certificate and the applicability of standard's requirements may be obtained by consulting the organisation.

(Eng. Francesco Sutera – Technical Director)

Certificate N°: **524/005**



ISO 9001 N° 009A PLS N° 079C
ISO 9001 N° 008D SGE N° 009M
ISO 9001 N° 009B EMAS N° 004P
ISO 9001 N° 008F GRG N° 008O
ISO 9001 N° 003T ISP N° 000E

Membro degli Accordi di Mutual Riconoscimento EA e IAF
Signatory of EA and IAF mutual Recognition Agreements

Bureau Veritas Italia S.p.A. – Via Miramare, 15 – 20126 Milan (MI) – ITALY

BUREAU VERITAS
Certification



Certification

Awarded to

AL WASAIL INDUSTRIAL COMPANY

Head Office:

Alwasail Building, King Abdullah Road, Hayal Maroj, Exit 10
PO Box No 21599 Riyadh 11485 K.S.A.

Operative Site:

PO Box No 5033 Buraidah Al-Gassim 51422 K.S.A.

Bureau Veritas Italia S.p.A.- Industry Division certifies that the following products:

Polyethylene (PE) structured wall piping systems

Joint method	Type	Area	SN	from DN/ID	to DN/ID
Coupler	B	U	4	100	200
Coupler	B	U	8	100	200

Brand:

AL WASAIL

Have been audited and found to be in accordance with the requirements of the:

EN 13476-3:2007+A1:2009

Plastics piping systems for non-pressure underground drainage and sewerage.
Part 3: Specifications for pipes and fittings with smooth internal and profiled external surface and the system, Type B

Certification issued in conformity to TQR-REG-02 Bureau Veritas Rev. 05 - Regolamento generale per la certificazione di conformità di prodotto.

Original Emission Date: 25/11/2014

Expiration date: 24/11/2017

The validity of this certificate is subject to a constant periodical surveillance and it can be checked on the following website:
www.certification.bureauveritas.it Further clarifications regarding the scope of this certificate and the applicability of standard's requirements may be obtained by consulting the organisation.



Yurki
Certificato n° 524/004

Bureau Veritas Italia S.p.A. - Industry Division Via Miramare, 15 - 20126 Milano - ITALIA

BUREAU VERITAS
Certification



Certificate of Conformity

Awarded to:

AL WASAIL INDUSTRIAL COMPANY

Head Office:

Alwasail Building, King Abdullah Road, Hayal Maroj, Exit 10
PO Box No 21599 Riyadh 11485 K.S.A.

Operative Site:

PO Box No 5033 Buraidah Al-Gassim 51422 K.S.A.

Bureau Veritas Italia S.p.A. certifies that the following products:

Electrofusion socket fitting (PE)

Designation	Figure	MOP	SDR	S	from DN	to DN
PE 100	Electrofusion Coupler	10	11	5	75	250

Commercial Brand:

AL WASAIL ELECTROFUSION

Compound codes:

PE100: B9I, P00

Have been evaluated and found in accordance with the requirements of the standard:

EN 1555-3:2010+A1:2012

Plastics piping systems for the supply of gaseous fuels
Polyethylene (PE) - Part 3: Fittings

Certificate issued in conformity to: RG-01-03 ACCREDIA Rev.00 and TQR-REG-02 Bureau Veritas Rev. 05 – Regulation for the certification of product / process / service.

Original Emission date: 16/06/2016
Current Emission date: 16/06/2016
Expiration date: 15/06/2019

The validity of this certificate is subject to a constant periodical surveillance and it can be checked on the following website: www.bureauveritas.it - Further clarifications regarding the scope of this certificate and the applicability of standard's requirements may be obtained by consulting the organisation.

(Eng. Francesco Sutera – Technical Director)

Certificate N°: **524/005**



ISO 9001 N° 009A PLS N° 079C
ISO 9001 N° 008D SGE N° 009M
ISO 9001 N° 009B EMAS N° 004P
ISO 9001 N° 008F GRG N° 008O
PDRS N° 003T ISP N° 000E

Membro degli Accordi di Mutuo Riconoscimento EA e IAF
Signatory of EA and IAF mutual Recognition Agreements

Bureau Veritas Italia S.p.A. – Via Miramare, 15 – 20126 Milan (MI) – ITALY

BUREAU VERITAS
Certification



Certificate of Conformity

Awarded to:

AL WASAIL INDUSTRIAL COMPANY

Head Office:

Alwasail Building, King Abdullah Road, Hayal Maroj, Exit 10
PO Box No 21599 Riyadh 11485 K.S.A.

Operative Site:

PO Box No 5033 Buraidah Al-Gassim 51422 K.S.A.

Bureau Veritas Italia S.p.A. certifies that the following products:

Electrofusion socket fitting (PE)

Designation	Figure	PN	SDR	S	from DN	to DN
PE 100	Electrofusion Coupler	16	11	5	75	250

Commercial Brand:

AL WASAIL ELECTROFUSION

Compound codes:

PE100: B9I, P00

Have been evaluated and found in accordance with the requirements of the standard:

EN 12201-3:2011+A1:2012

Plastics piping systems for water supply, and for drainage and sewerage under pressure -
Polyethylene (PE) - Part 3: Fittings

Certificate issued in conformity to: RG-01-03 ACCREDIA Rev.00 and TQR-REG-02 Bureau Veritas Rev. 05 – Regulation for the certification of product / process / service.

Original Emission date: 16/06/2016

Current Emission date: 16/06/2016

Expiration date: 15/06/2019

The validity of this certificate is subject to a constant periodical surveillance and it can be checked on the following website: www.bureauveritas.it - Further clarifications regarding the scope of this certificate and the applicability of standard's requirements may be obtained by consulting the organisation.

(Eng. Francesco Sutera – Technical Director)

Certificate N°: **524/006**



ISO 9001 N° 0094 PLS N° 076C
ISO 9001 N° 0088 SGE N° 009H
ISO 9001 N° 0098 BRAS N° 0045
ISO 9001 N° 008F GHG N° 0080
ISO 9001 N° 0031 ISP N° 008E

Membro degli Accordi di Mutuo Riconoscimento EA e IAF
Signatory of EA and IAF Mutual Recognition Agreements

Bureau Veritas Italia S.p.A. – Via Miramare, 15 – 20126 Milan (MI) – ITALY

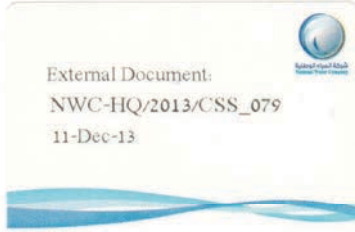

بسم الله الرحمن الرحيم.



شركة المياه الوطنية
National Water Company

المحترمين

السادة / شركة الوسائل الصناعية

السلام عليكم ورحمة الله وبركاته،،،

إشارة إلى طلبكم اعتمادكم كمورد لمنتجات (أنابيب البولي إيثيلين) المنتجة من قبل مصنعكم الكائن بمدينة بريدة.

وبناء على توصيات اللجنة الفنية، نفيديكم باعتماد منتجاتكم من أنابيب البولي إيثيلين عالي الكثافة لمشاريع المياه وذلك للأقطار من (٢٠-٢٠٠) ملم وذلك لمدة عام من تاريخه، على أن يتم والتعاقد مع طرف ثالث (Third Party) لاختبار الأنابيب عند وصولها للتأكد من مطابقتها للمواصفات الفنية، على أن لا تتحمل شركة المياه الوطنية أي تكلفة لهذه الاختبارات، مع ضمان حق شركة المياه الوطنية في حال ظهور أي عيوب في المنتجات

ودمت برعاية الله،،،

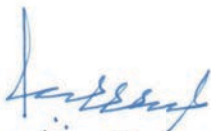
المهندس / خالد بن أحمد الشنقيطي
المدير التنفيذي للخدمات المساندة

· Saudi Arabian Oil Company
· Supplier Registration Unit
· Supplier Relationship Management Division
· Project & Strategic Purchasing
· Wing A.C-143, North Park 1
· Dhahran 31311, Saudi Arabia

August 22, 2013

SRQU-156-13

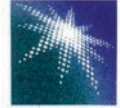

أرامكو السعودية
Saudi Aramco

SALEH A. ALMUSHEKIH, Managing Director
AlWasail Irrigation Systems Factory (Branch of AlWasail Industrial Company)
P.O. BOX 5033
BURAYDAH 51422

Fax 011-450-8166

Mr. AlMushekih,

We are pleased to inform you that your company is included in the Saudi Aramco Supplier Information System under Vendor No. **10027540**, Plant No. **30006591** for the following product provided your company continues to meet relevant Saudi Arabian and Saudi Aramco standards:

9COM	Description
6000000039*	Pipe; Non-metallic; Metric size; Thermoplastic

*Approved with limitations.

This approval, however, should not be construed as a commitment by Saudi Aramco to purchase from you, but your company will have the opportunity along with other approved sources to respond to requests for submitting proposals in accordance with Saudi Aramco's established policies and procedures.

We would like to thank you for your interest in Saudi Aramco and take this opportunity to reiterate that it is Saudi Aramco's policy to encourage the use of nationally manufactured materials.

Should you have any questions, please contact Husain M. Al-Saihati on 874-0321.

ALI M. AL-HUSSAIN, Supervisor
Supplier Relations & Qualification Unit

It is the responsibility of the supplier to notify Saudi Aramco Supplier Relations & Qualification Unit of the following

1. Change of Name/Address/Owner(s).
2. Any change of the supplier location (sub sourcing fabrication of major components).
3. Discontinue of fabrication or supply of approved commodities (9COMs, 9CATS and/or MSGs).

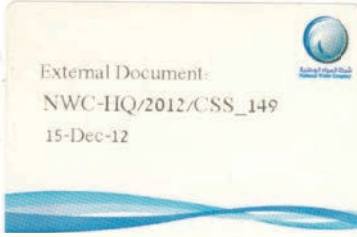

بسم الله الرحمن الرحيم



المحترمين

السادة / شركة الوسائل الصناعية

السلام عليكم ورحمة الله وبركاته،،،

إشارة إلى طلبكم اعتمادكم كمورد لمنتجات (FUSION GROUP) من المملكة المتحدة من قطع البولي إيثيلين عالي الكثافة بطريقتي اللحام الكهربائي (ELECTORO FUSSION FITTINGS) وبطريقة (BUTT WELDING).

وبناء على تقرير اللجنة التي قامت بزيارة المصنع نفيديكم باعتماد قطع البولي إيثيلين عالي الكثافة بطريقتي اللحام الكهربائي (ELECTORO FUSSION FITTINGS) وكذلك (BUTT WELDING) من مادة HDPE من إنتاج (FUSION GROUP) من المملكة المتحدة وذلك للأقطار من (١٩ ملم إلى ٢٠٠ ملم) حيث أن الانابيب المستخدمة من مادة HDPE في المشاريع حتى قطر (٢٠٠ ملم)، على أن يتم إرسال شهادة معاينة (Inspection Certification) من قبل جهة مختصة وذلك لاختبار الوصلات عند توريدها والتعاقد مع طرف ثالث (Third Party) لاختبار الوصلات عند وصولها، كما يتم ارفاق شهادة المنشأ وكذلك شهادات المواد الخام المستخدمة في التصنيع مع كل شحنة، على أن لا تتحمل شركة المياه الوطنية أي تكلفة لهذه الاختبارات.

ودمتم برعاية الله،،،

المهندس / خالد بن أحمد الشنقيطي
المدير التنفيذي للخدمات المساندة



WaterMark Level 1

Certificate of Conformity

Australian Certification Services Pty Ltd grants to the WaterMark User:

Al Wasail Industrial Co.
Trading as Al Wasail Industrial Co.

the right to use the WaterMark as shown above in conjunction with the Certificate No. on product/s as identified in the WaterMark Schedule and as listed on the WaterMark database www.abcb.gov.au/product-certification which have been shown to comply with the relevant Standard/s and level of certification referred to below. The WaterMark User is granted a licence to use the WaterMark subject to the rules governing the use of the WaterMark.

Product Type: Polyethylene (PE) Fittings
Evaluated to: AS/NZS 4129:2008 Fittings for use with polyethylene (PE) pipes for pressure applications

Issue Date: 12th August 2014
Initial Issue Date: 12th August 2014
Expiry Date: 11th August 2019

Paul Greig
General Manager

Certificate No.: 23170

This certificate remains the property of Australian Certification Services Pty Ltd
WaterMark Level 1 certification is a conformity assessment scheme based on ISO Guide 67 (system 5)

Page 1 of 9



Australian Certification Services Pty Ltd ABN 37 121 022 366
SSHED Studio 5 1 Pitt St, Loftus NSW 2232 PO Box 627 Jannali, NSW
2226 AUSTRALIA
Phone: +61 2 9545 7412 Email: admin@certificationservices.com.au
www.certificationservices.com.au

JAS-ANZ



www.jas-anz.org/register

Certificate Number: 23170
Issue Date: 12th August 2014
Issue: 01 Revision: 00



Certificate of Compliance

This certificate is issued for the following:

Polyethylene Pipe

Product Designation	Nominal Pipe Size, mm	Pressure Rating, psi (bar)
Pipe	50, 63, 75, 90, 110, 125, 160, 180, 200, 225, 250	150 (10.35)

Prepared for:

Al-Wasail Industrial Co.
 5033 Industrial City
 Buraidah Al-Gassim 51422
 Saudi Arabia

Manufactured at:

Al-Wasail Industrial Co.
 5033 Industrial City
 Buraidah Al-Gassim 51422
 Saudi Arabia

FM Approvals Class: 1613

Approval Identification: 0003051548

Approval Granted: March 22, 2015

To verify the availability of the Approved product, please refer to www.approvalguide.com

Said Approval is subject to satisfactory field performance, continuing Surveillance Audits, and strict conformity to the constructions as shown in the Approval Guide, an online resource of FM Approvals.

Richard B. Dunne
 Manager of Fire Protection
 FM Approvals
 1151 Boston-Providence Turnpike
 Norwood, MA 02062



Member of the FM Global Group

الرقم: ١٤٣٥\١١\١١١٥
التاريخ: ١٤٣٥-١٢-٠١
المرفقات:



المملكة العربية السعودية
وزارة المياه والكهرباء
مكتب الوزير
(٢٧٦)
(٧٠٠١٤٣٩٩٢١)

سعادة وكيل الوزارة لشئون المياه
سعادة الرئيس التنفيذي لشركة المياه الوطنية
سعادة المدير العام لإدارة الصرف الصحي
سعادة المدير العام للمياه بمنطقة الرياض
سعادة المشرف العام على المياه بمنطقة مكة المكرمة
سعادة المدير العام للمياه بمنطقة المدينة المنورة
سعادة المدير العام للمياه بمنطقة القصيم
سعادة المدير العام للمياه بالمنطقة الشرقية
سعادة المدير العام للمياه بمنطقة عسير
سعادة المدير العام للمياه بمنطقة تبوك
سعادة المدير العام للمياه بمنطقة حائل
سعادة المدير العام للمياه بمنطقة الحدود الشمالية
سعادة المدير العام للمياه بمنطقة جازان
سعادة المدير العام للمياه بمنطقة نجران
سعادة المدير العام للمياه بمنطقة الباحة
سعادة المدير العام للمياه بمنطقة الجوف

وفقه الله
وفقه الله
وفقه الله
وفقه الله
وفقه الله
وفقه الله
وفقه الله
وفقه الله
وفقه الله
وفقه الله
وفقه الله
وفقه الله
وفقه الله
وفقه الله
وفقه الله
وفقه الله
وفقه الله
وفقه الله
وفقه الله
وفقه الله

السلام عليكم ورحمة الله وبركاته

إلحاقاً للتعميم رقم (١/٧٨٠) بتاريخ ١٠/٢٨/١٤٣٠هـ، بشأن اعتماد منتجات شركة الوسائل الصناعية المحدودة لأنابيب البولي إيثيلين ، برفقه خطاب شركة المياه الوطنية رقم (٣٥/HQ/٤٩٤٥٨) بتاريخ ١١/٢٥/١٤٣٥هـ، المشار فيه إلى خطاب المديرية العامة للمياه بمنطقة الرياض رقم (١٠٠٢٨/٢٥٣٦) بتاريخ ١٠/١٥/١٤٣٥هـ، بشأن طلب تجديد اعتماد منتجات الشركة من أنابيب البولي إيثيلين للاقطار (٢٥٠ - ٢٥٠) ملم ، وحيث أفادت شركة المياه الوطنية والمديرية العامة للمياه بمنطقة الرياض باعتماد منتجات الشركة لتلك الأنابيب لمدة عامين .

أمل الإطلاع ، والتوجيه باعتماد منتجات شركة الوسائل الصناعية المحدودة من أنابيب البولي إيثيلين حسب الاقطار المشار إليها أعلاه لمدة عامين من تاريخه عند الحاجة إليها ، على أن تكون التكلفة مناسبة ، والتعاقد مع مختبر محايد ومعتمد لاختبار الأنابيب عند وصولها للتأكد من مطابقتها للمواصفات الفنية ، على ألا تتحمل الوزارة أي تكلفة لهذه الاختبارات ، ورفع أي ملحوظات عند المتابعة الدورية.

مع أطيب تحياتي ، ،



نسخة لشركة الوسائل الصناعية المحدودة لأنابيب البولي إيثيلين.

Alwasail Sales Branches

Location	P.O BOX	Telephone Number	Fax Number	Mobile 1	Mobile 2	Name
Buraidah (Head Office)	124	0160163821901/3821785	0163811203			بريدة (المكتب الرئيسي)
Buraidah (Main Branch)	124	0163816658	0163811306	0550305456	0500561985	بريدة 1
Buraidah (AlMuwattah)	124	0163249419	0163257076	0506390297	0506402491	بريدة 2
Dammam	8893	0138171375	0138176347	0500590147	0506401979	الدمام
Hail	2393	0165435219	0165322138-	0506317256	0539000617	حائل
Hafouf		0135825534	0135825634	0506314021		الهفوف
Jeddah 1	6963	0126654536	0126657473	0503135068	0500809917	جدة 1
Jeddah 2	6963	0122275735	0122274659	0506420914	0506423598	جدة 2
Jizan (Sabia)	112	0173274880	0173274883	0506346456	0506471179	جيزان
Jouf	1083	0146244076	0146246840	0556523214	0506367925	الجوف
Kharj	1606	0115501616	0115510458	0506348974		الخرج
Meddina	250	0148457277	0148461493	0506415610	0500562497	المدينة
Najran	1317	0175440611	0175441986	0506348947		نجران
Onaizah	1509	0163610128	0163610128	0506418763	0555638188	عنيزة
Riyadh Main Branch	21599	01132-4508431	0114508422	0506359145	0506354815	الرياض (فرع الرئيسي)
Riyadh Salam Street	21599	0114114679	0114111914	0504235324		فرع الرياض (شارع السلام)
Tabuk	2008	0144211389	0144288374	0506358753	0550560184	تبوك
Taif	7042	0127402179	0127402179	0506403967		الطائف
Wadi AlDawasir	525	0117845051	0117845051	0506419643		وادي الدواسر
Zulfi	725	0164224927	0164223421	0506351903		الزلفي
Qaryah Alulaya		0133861225	0133861960	0555175623		قرية العليا
Khamis Musheet		0172371622	0172371260	0502964282		خميس مشيط
Sajer		0148846636	0148846636	0504898933		العلا
ALola				0555837887		ساجر
EXPORT	21599	0114508431EXT 4423	0114548057	0506375685		تصدير
Egypt				0020062900600		مصر
U.A.E	48980	0097142668040	0097142668035	00971506117612	00971506506063	الإمارات



ALWASAIL



الوسائل

Alwasail Industrial Co. شركة الوسائل الصناعية



الإدارة العامة للتسويق والمبيعات
القصيم - بريدة - طريق الملك عبدالعزيز
تليفون +966 163833032 فاكس +966 163824997
مكتب تنسيق المبيعات وعلاقات العملاء
والإشراف على المعارض
+ 966 506387882

General Department of Marketing and Sales
Qassim - Buraidah - King Abdul Aziz Street
Tel. +966 16 3833032 - Fax +966 16 3824997
Sales Coordinator & CRM
"Supervision of Exhibitions"
+966 506387882
E-mail : ghassan@al-wassel.com

شركة الوسائل الصناعية
السعودية - الرياض - ص.ب 21599 الرمز 11485
تليفون +966 11 4508431 / 32/ 33 / 34
فاكس +966 11 4508435/ +966 11 4508166
قسم التصدير جوال : +966 506375685
Al-Wasail Industrial Co.

Saudi Arabia, Riyadh, P.O.Box 21599, Code 11485
Tel. +966 11 4508431 / 32/ 33 / 34
Fax +966 11 4508166 / +966 11 4508430
International Marketing
Mob : +966 506375685
E-mail : abdulhameed@alwasail.com

الهاتف المجاني 920027777

E-mail: info@alwasail.com
www.alwasail.com